

SUMOflo[®]

SINGLE-USE CORIOLIS MASS FLOW METER

Description

The latest version of the Malema Sensors[®] SumoFlo[®] CPFM-8103-series Single-Use Coriolis Flow Meters with improved electronics are specifically designed for measuring mass and volumetric flow rates of liquids in bio-pharmaceutical and other applications that require all gamma-compatible wetted surfaces. The fluid contacting surfaces are made of unreinforced polyether ether ketone (PEEK) that meet USP Class VI, USP 661, and USP 788 standards.

The CE compliant SumoFlo[®] series Coriolis Flow Meters include the single-use sensor assembly, supporting electronics, sensor mounting enclosure, and a graphical user interface (GUI). Integral temperature sensors provide feedback to the electronics that allow temperature compensation to ensure the measurement accuracy regardless of temperature changes to the application fluid.

U.S. PATENTS 8404076 & 8887578 & 9677921 & 10209113
JAPANESE PATENTS 5602884 & 6581309.
CHINESE PATENTS ZL 201480046308.8 & ZL 201680077990.6.
TAIWANESE PATENTS I657231 & I528021.
EUROPEAN UNION PATENT 3036083. OTHER PATENTS PENDING
See www.malema.com/patents for latest information

Key Features

- Accuracy: $\pm 1\%$ of mass flow rate reading; unaffected by flow regime or variations to the velocity profile
- Multiple size sensors for flow ranges from 50 g/min (ml/min) to 100 kg/min (l/min)
- Fluid measurement performance is independent of fluid properties
- USP Class VI wetted materials
- PEEK sensor is compatible with gamma irradiation to 40 kGy

Measurement Principle

Fluid flows into the sensor consisting of two flow sensitive elements which are vibrated relative to one another – similar to the tines of a tuning fork. Fluid interacts with the sensor dynamically in such a way that the sensor's response is immune to the fluid's chemical and physical properties, flow regime, or variations in flow velocity profile. Fluid mass flow rate is determined by measuring the relative motion of the vibrating flow sensitive elements.

Applications

- Chromatography
- Cell Culture
- Depth Filtration and Tangential Flow Filtration
- Continuous Processing

CPFPM-8103

Typical Block Diagram

Coriolis Mass Flow Meter

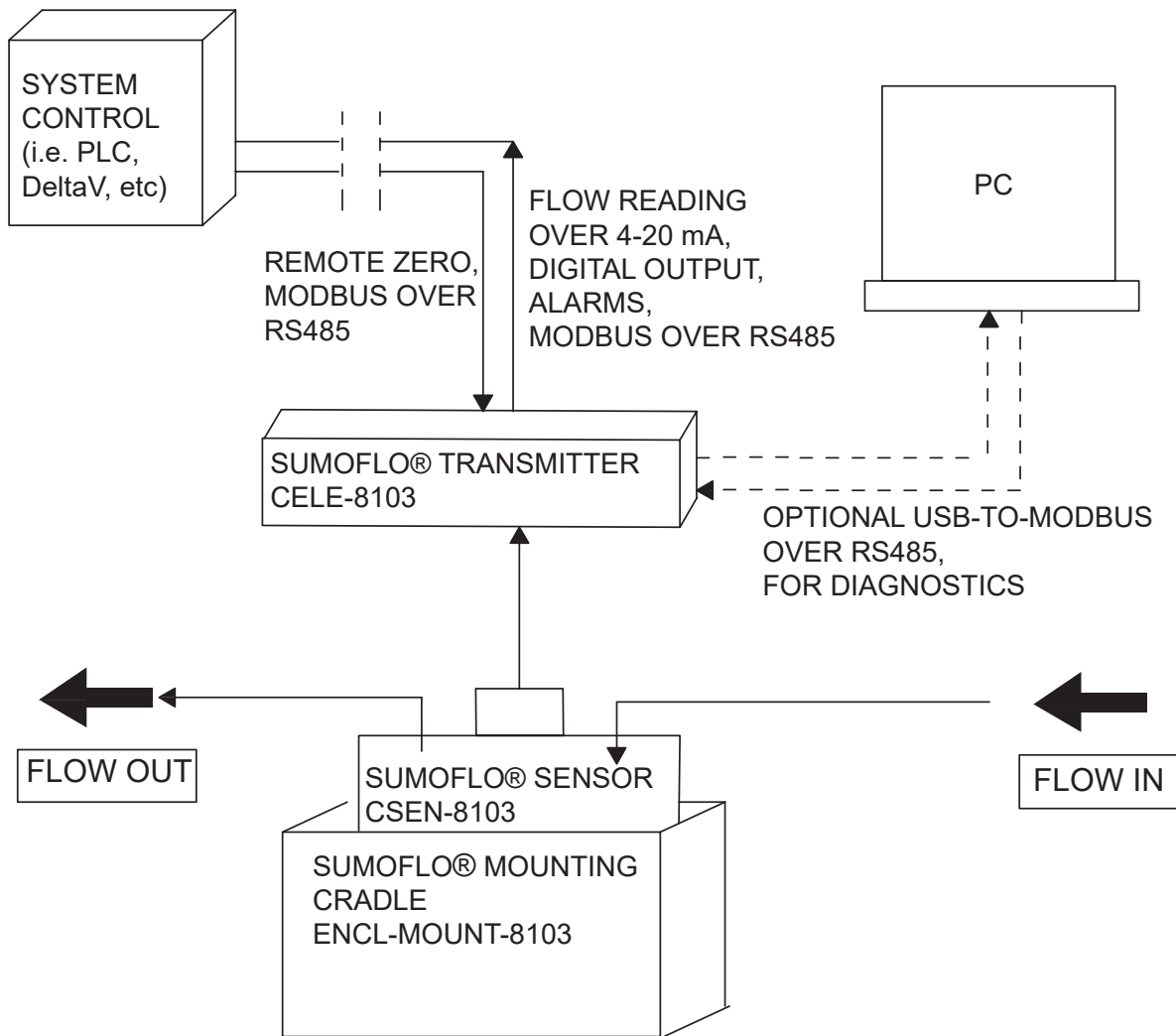

A SumoFlo® CPFPM-8103-series Coriolis flow meter consists of three components: the single-use Coriolis flow sensor, the durable transmitter, and the durable mounting cradle, as well as the durable cables to connect the transmitter to the sensor and the transmitter to the system control device. When properly installed in the mounting cradle, the SumoFlo® flow meter meets CE specifications.

Optional durable components include a stand to mount the cradle for stand alone installation, an RS485-to-USB connector, and a Windows 10 Pro Laptop Computer running Malema Coriolis GUI software. Stand-alone remote displays are also available. Contact Malema for additional information if needed.

Sensor Style	Description	Electrical Connections	Fluid Connections
C	Cradle-Mount Sensor	Top (same side as fluid connections)	6° from vertical
P	Panel-Mount Sensor	Bottom (opposite side as fluid connections)	6° from vertical
R	Standard Inline Sensor	Either top or bottom	Inline (90° from vertical)
T	Tall Inline Sensor	Either top or bottom	Inline (90° from vertical)

Measurement Specifications

Model CSEN-8103-**	031	062	063	082	152	153
Accuracy	±1% of rate for 10% to 100% of full scale rated flow rate ±(1% of rate + Z.O.S) for < 10% of full scale rated flow rate					
Temperature	Ambient: 0°–50°C Fluid: 2°–40°C					
Operating Pressure	30 psig (207 kPa gauge) max.	80 psig (550 kPa gauge) max.				
Flow Range *	0.05 – 1.5 kg/min (l/min)	0.5 – 5 kg/min (l/min)	0.9 – 9 kg/min (l/min)	2 – 20 kg/min (l/min)	6 – 60 kg/min (l/min)	10 – 100 kg/min (l/min)
Zero Offset Stability (Z.O.S.)	1.5 g/min	2 g/min	4 g/min	10 g/min	20 g/min	40 g/min

* Check page 20 for special flow ranges for R & T style sensors. Lower minimum flow rates available with special calibration fee.

Material Specifications

Model CSEN-8103-**	031	062	063	082	152	153
Process Connections *	1/8" barb 1/4" barb	1/4" barb	3/8" barb 3/8" Mini TC	1/2" barb 1/2" Mini TC	3/4" barb 3/4" Mini TC	1" barb 1"-1.5" TC
Wetted Materials	Unreinforced PEEK (Polyether ether ketone), 316L Stainless Steel (for temperature sensor only), Silicone. All polymeric wetted materials are USP Class VI compliant.					
Interconnecting Cable Length	Standard 3 m; For other lengths please consult the factory.					
Ingress Rating For Connectors	IP65					

* Consult the factory for other types of process connection options.

Electrical Specifications

Supply Voltage	24 V DC ±10%
Power Consumption	Max 6 W
Programming	Operator Parameter configuration through configuration port with a PC
Analog Output Module	1x 4–20 mA, 2x 4–20 mA, or 4x 4–20 mA
Digital Input/Output Module	0x D/O, 1x D/O, or 2x D/O; Configurable as Frequency or Digital I/O
Frequency Output	0 to 10 kHz proportional to flow rate
Digital Output over MODBUS *	Mass Flow Rate, Volumetric Flow Rate**, Density**, Temperature ***

* Requires CELE-8103 model configured for MODBUS communications.

** Requires CELE-8103 and CSEN-8103 models configured for density measurement.

*** Requires CELE-8103 and CSEN-8103 models configured for temperature compensation.

Certifications/Compliances

USP Class VI Material Certification	CE Compliance via the following testing: 1. EN61000-4-2: Electrostatic Discharge 2. EN61000-4-3: Radiated Immunity (and Radiated Emissions) 3. EN61000-4-4: Electrical Fast Transients 4. EN61000-4-5: Surge – Power Line 5. EN61000-4-6: Conducted Immunity
USP 661 for Containers/Plastics	
USP 788 for Containers/Plastics	
Directive 2011/65/EU (RoHS)	

Mounting Orientation

The Malema Sensors® SumoFlo® series Coriolis flow meters can be mounted in vertical or horizontal orientations. For range codes 062 and larger with vertical inlet and outlet ports, when the flow sensor is mounted horizontally — as shown below — the angled fluid inlet and outlet ports allow for self-draining in one direction.

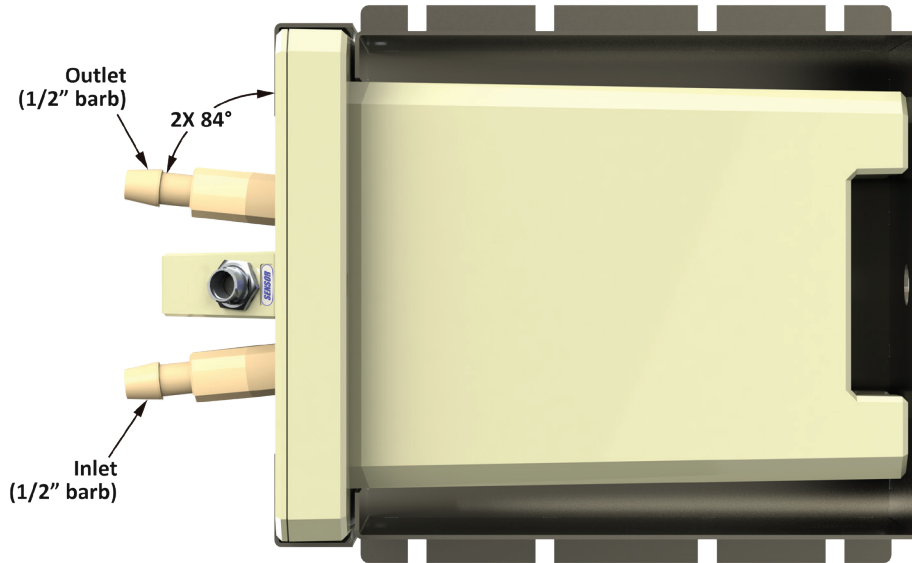

Dimensional Drawings

For reference only

CELE-8103 Transmitter

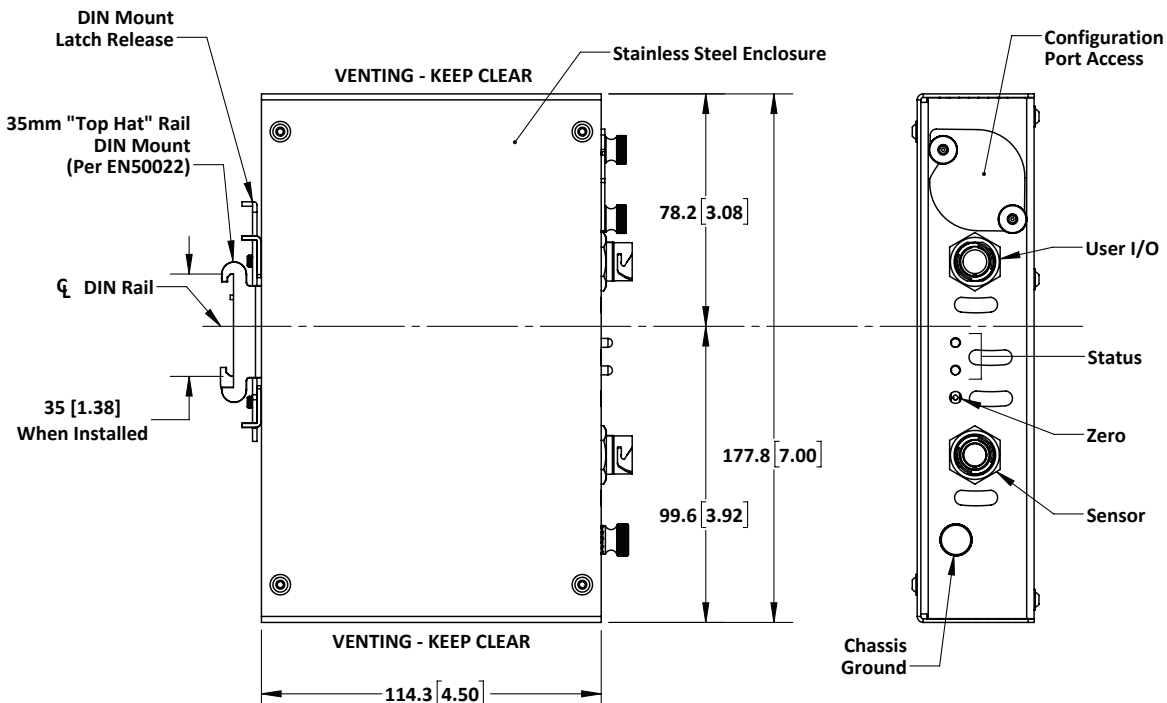
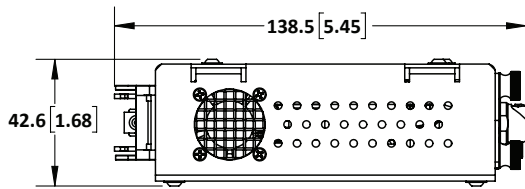

Dimensional Drawings

For reference only

Note: Mounting Cradle is required for CE compliance

CSEN-8103-RA062 Sensor (0.15 – 5 kg/min or l/min, 1/4")

1/4" Barb Connections, Inline Configuration

R

1/4"
BARB

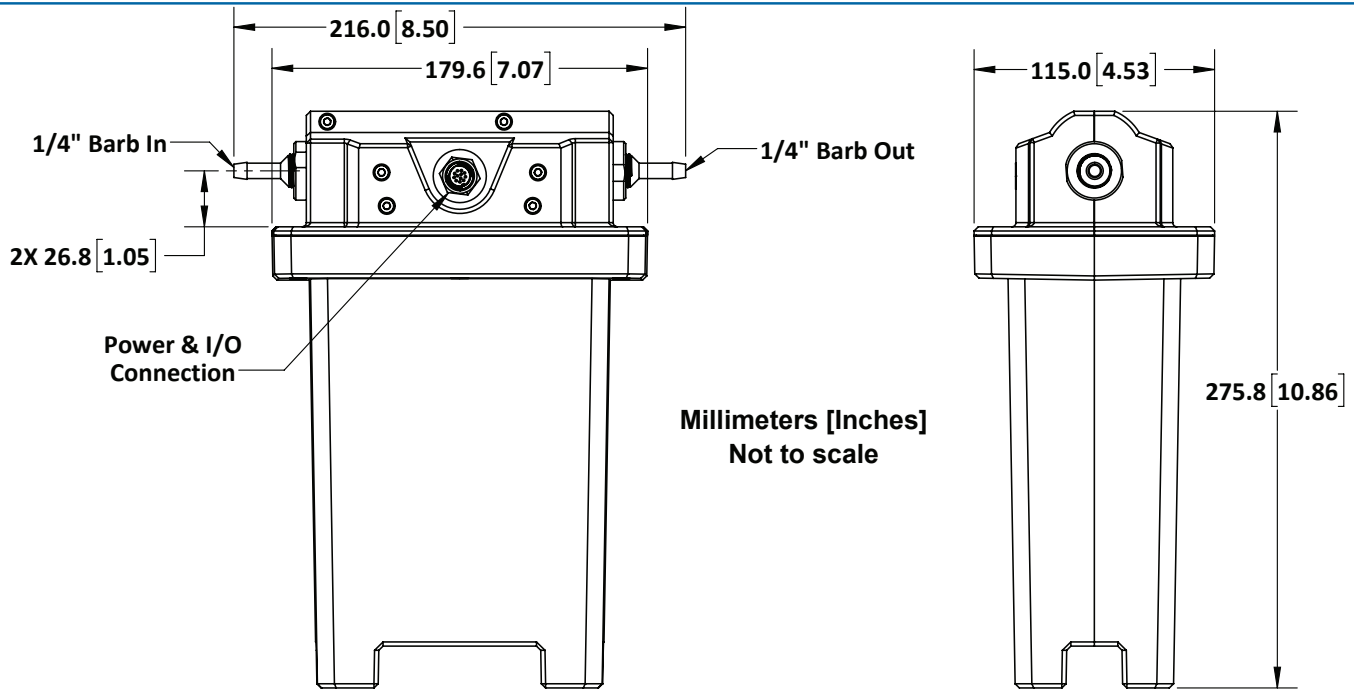

CSEN-8103-RA063 Sensor (0.18 – 9 kg/min or l/min, 3/8")

3/8" Barb Connections, Inline Configuration

R

3/8"
BARB

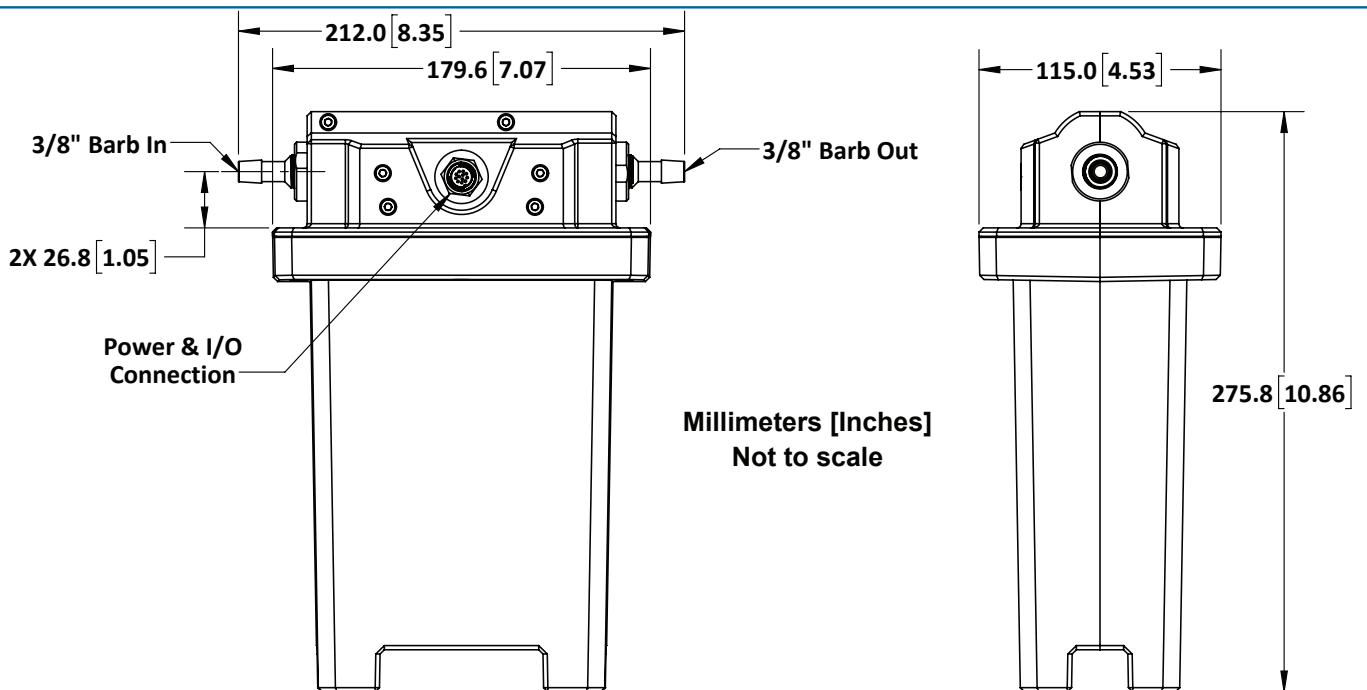

Dimensional Drawings

For reference only

Note: Mounting Cradle is required for CE compliance

CSEN-8103-RA082 Sensor (0.4 – 20 kg/min or l/min, 1/2")
 1/2" Barb Connections, Inline Configuration

R
 1/2"
 BARB

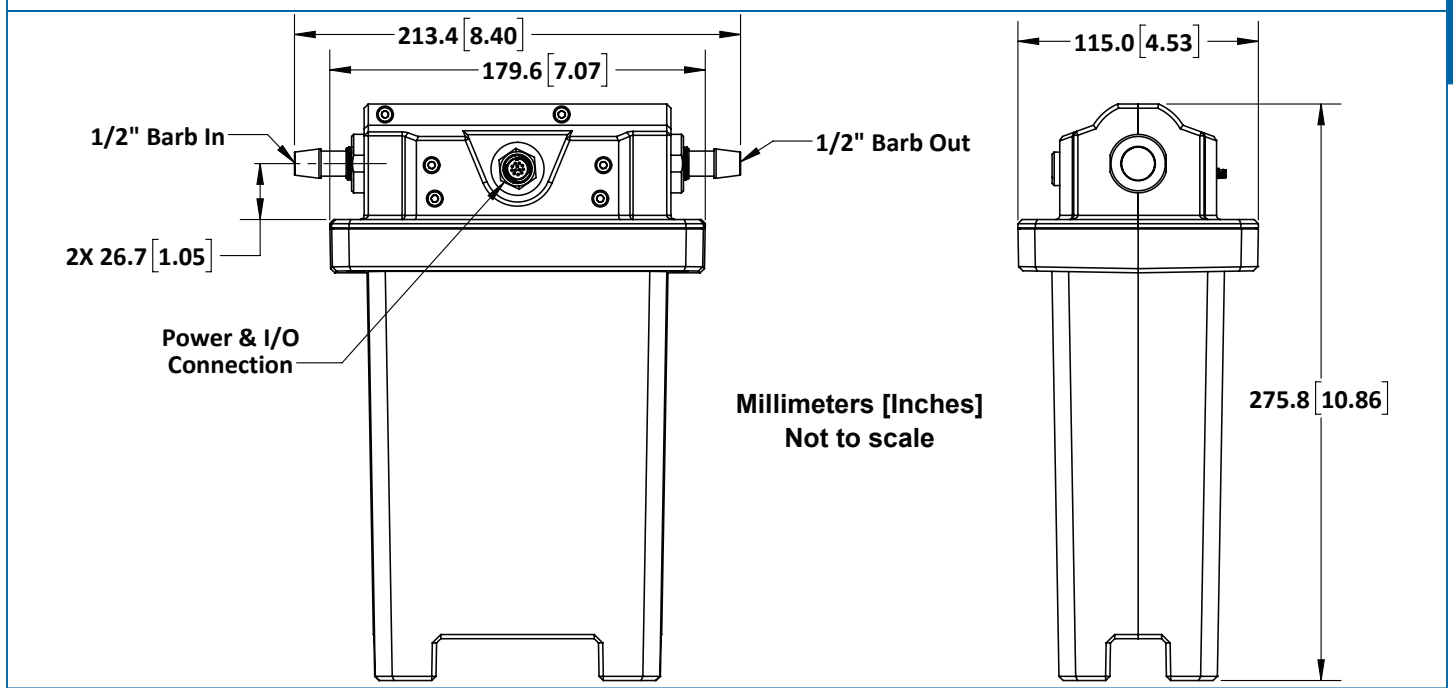

CSEN-8103-RA152 Sensor (6 – 60 kg/min or l/min, 3/4")
 3/4" Barb Connections, Inline Configuration

R
 3/4"
 BARB

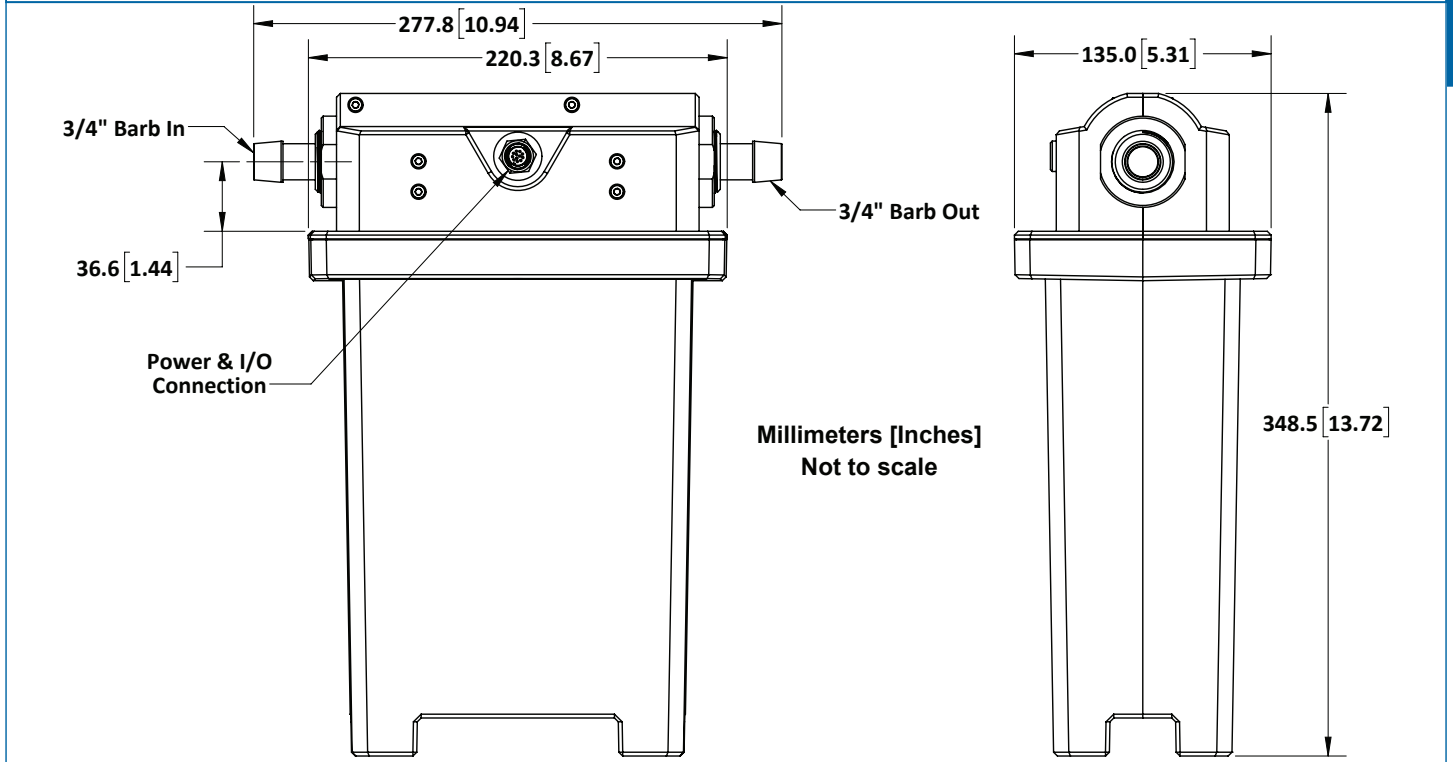

Dimensional Drawings

For reference only

Note: Mounting Cradle is required for CE compliance

CSEN-8103-RA153 Sensor (10 – 100 kg/min or l/min, 1")
1" Barb Connections, Inline Configuration

R

1" BARB

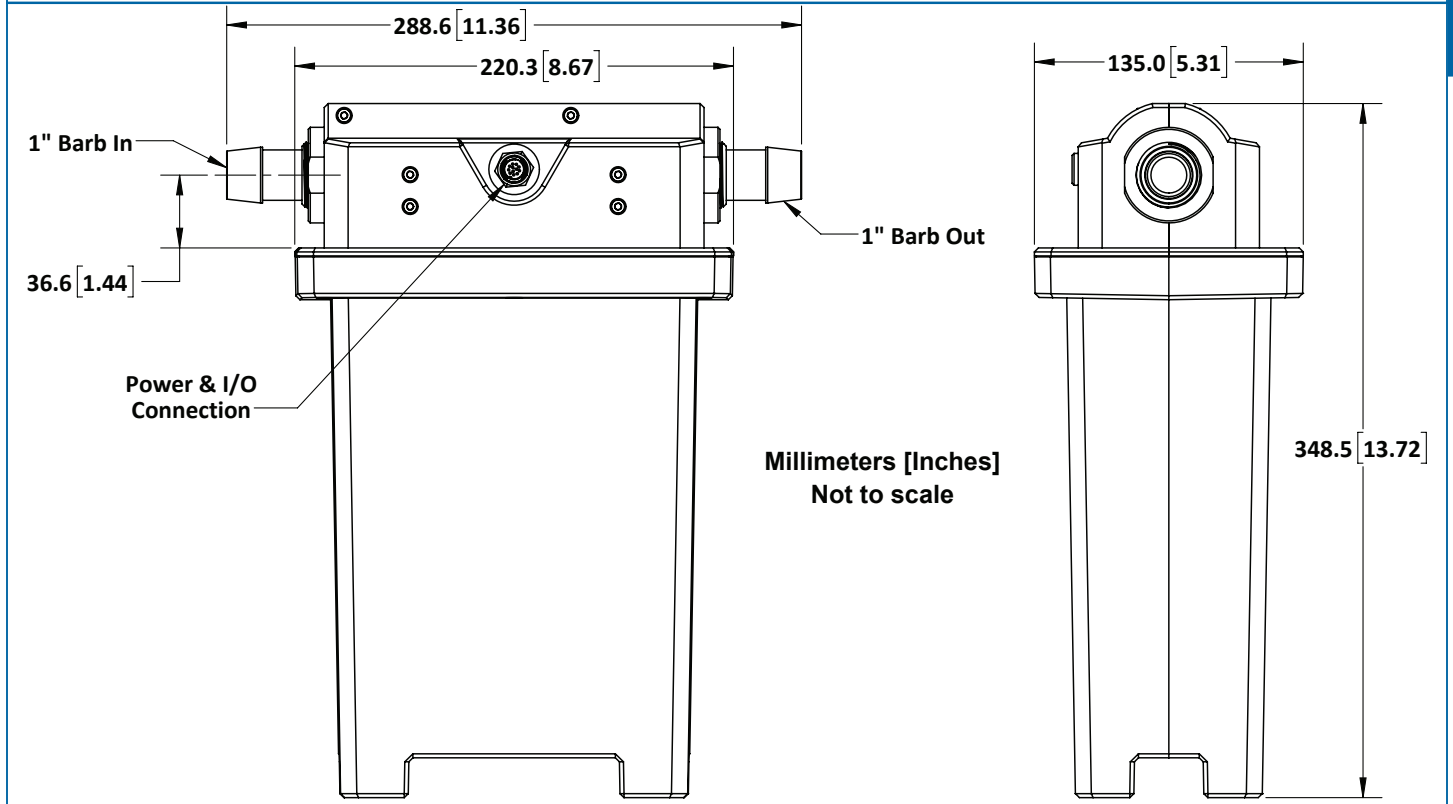

Dimensional Drawings

For reference only

Note: Mounting Cradle is required for CE compliance

CSEN-8103-CA031 Sensor (0.05 – 1.5 kg/min or l/min, 1/8" barb)
 1/8" Barb Connections, Standard Vertical Inlets Configuration

C
 1/8" BARB

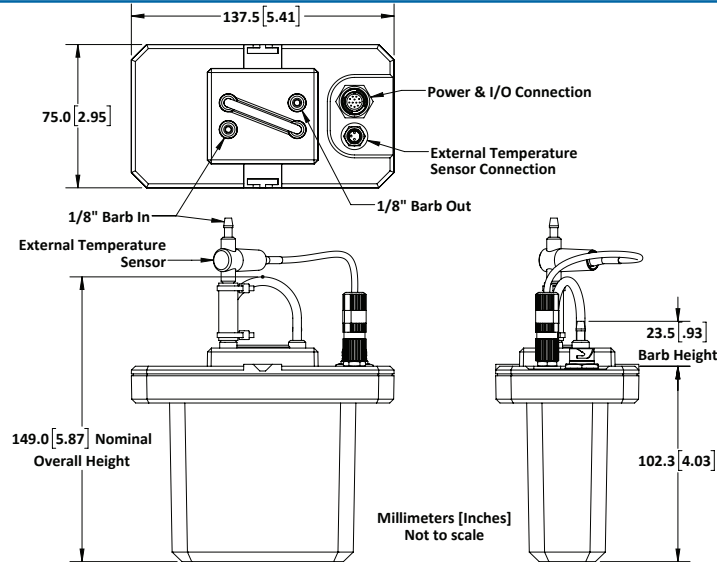

CSEN-8103-CA062 Sensor (0.5 – 5 kg/min or l/min, 1/4" barb)
 1/4" Barb Connections, Standard Vertical Inlets Configuration

C
 1/4" BARB

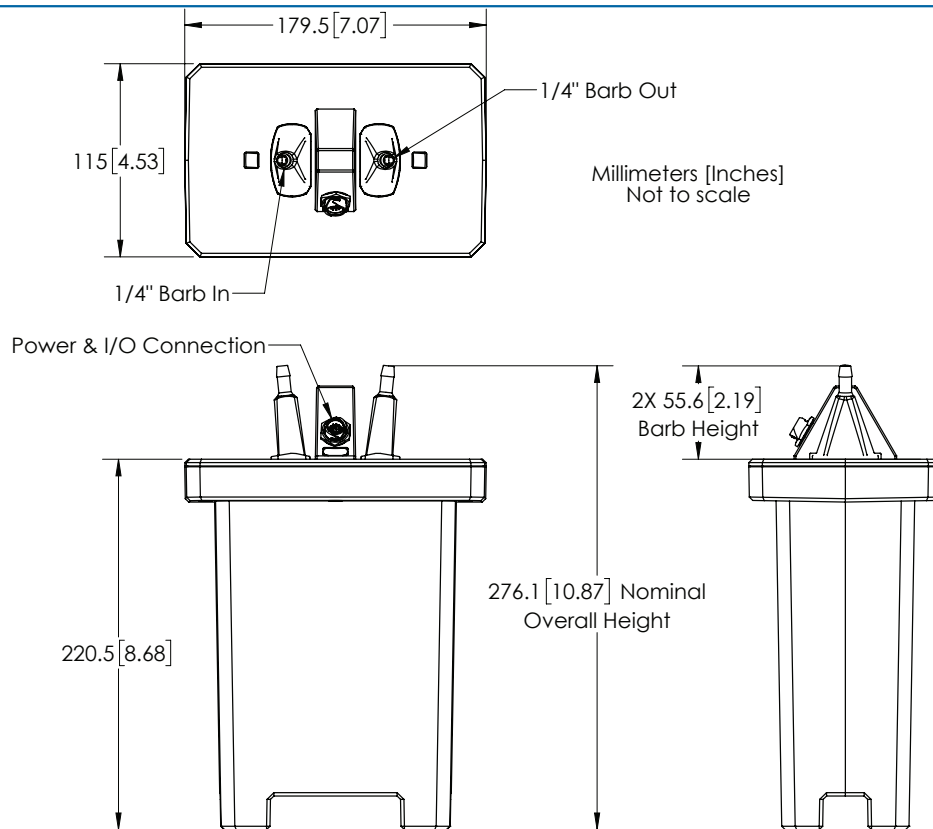

Dimensional Drawings

For reference only

Note: Mounting Cradle is required for CE compliance

CSEN-8103-CA063 Sensor (0.9 – 9 kg/min or l/min, 3/8" barb)
 3/8" Barb Connections, Standard Vertical Inlets Configuration

C
 3/8"
 BARB

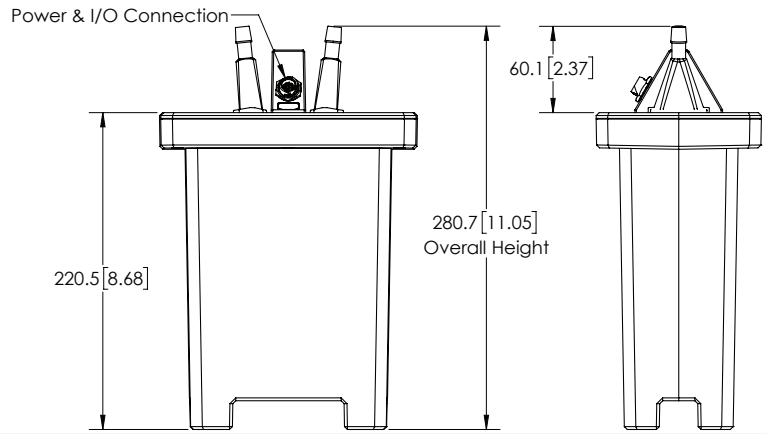
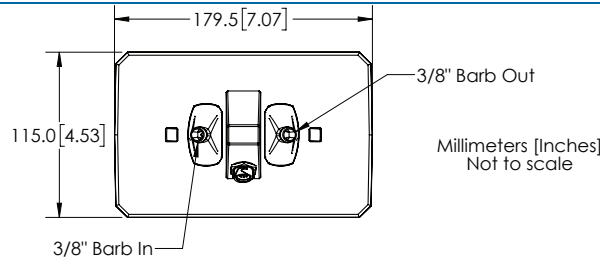

CSEN-8103-CA082 Sensor (2 – 20 kg/min or l/min, 1/2" MiniTC)
 1/2" Mini-Tri-Clamp Connections, Standard Vertical Inlets Configuration

C
 1/2"
 M-TC

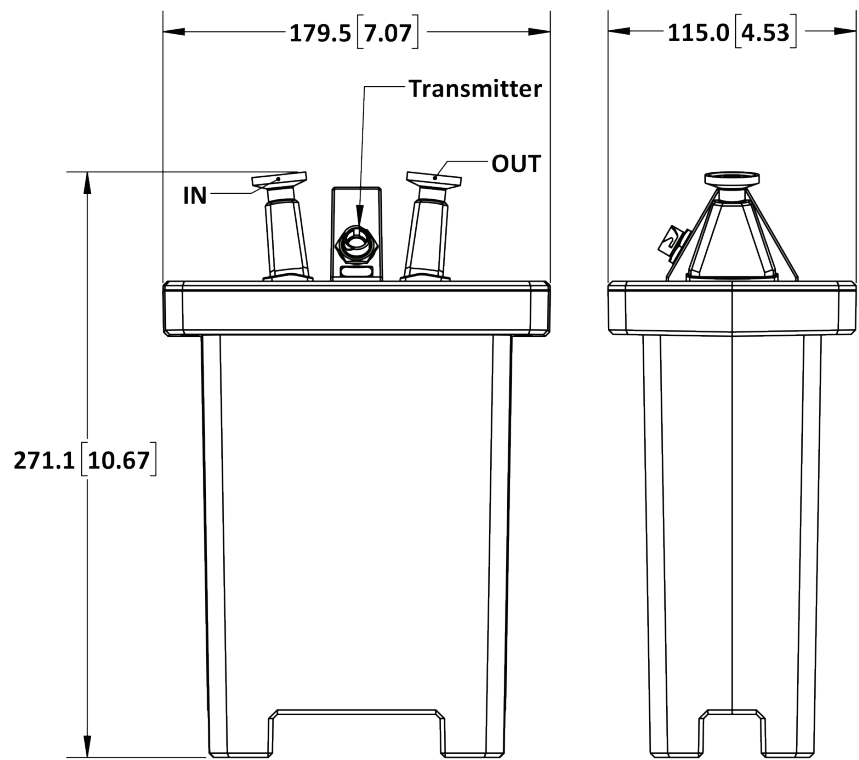

Dimensional Drawings

For reference only

Note: Mounting Cradle is required for CE compliance

CSEN-8103-CA082 Sensor (2 – 20 kg/min or l/min, 1/2" barb)

1/2" Barb Connections, Standard Vertical Inlets Configuration

C

1/2" BARB

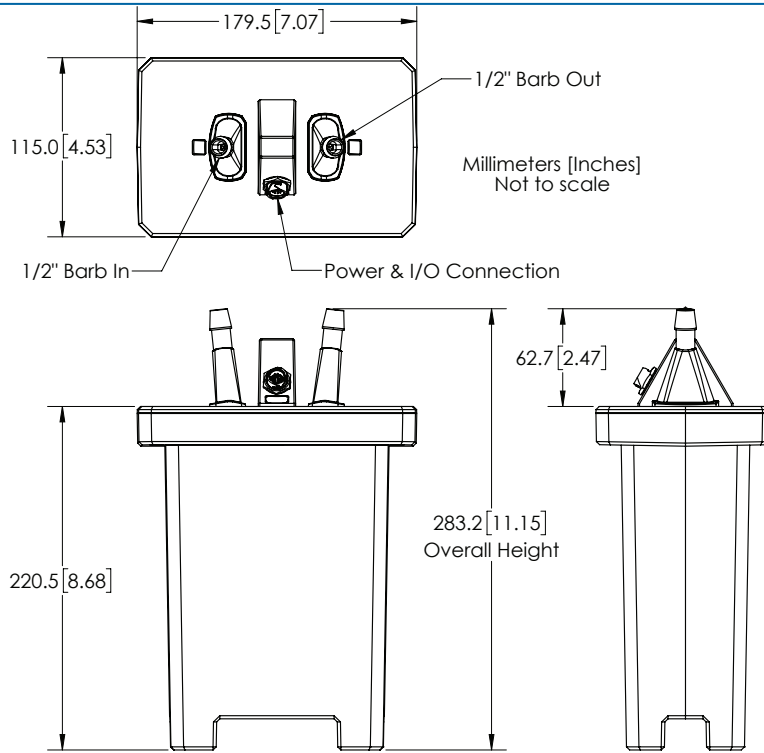

CSEN-8103-CA152 Sensor (6 – 60 kg/min or l/min, 3/4" MiniTC)

3/4" Mini-Tri-Clamp Connections, Standard Vertical Inlets Configuration

C

3/4" M-TC

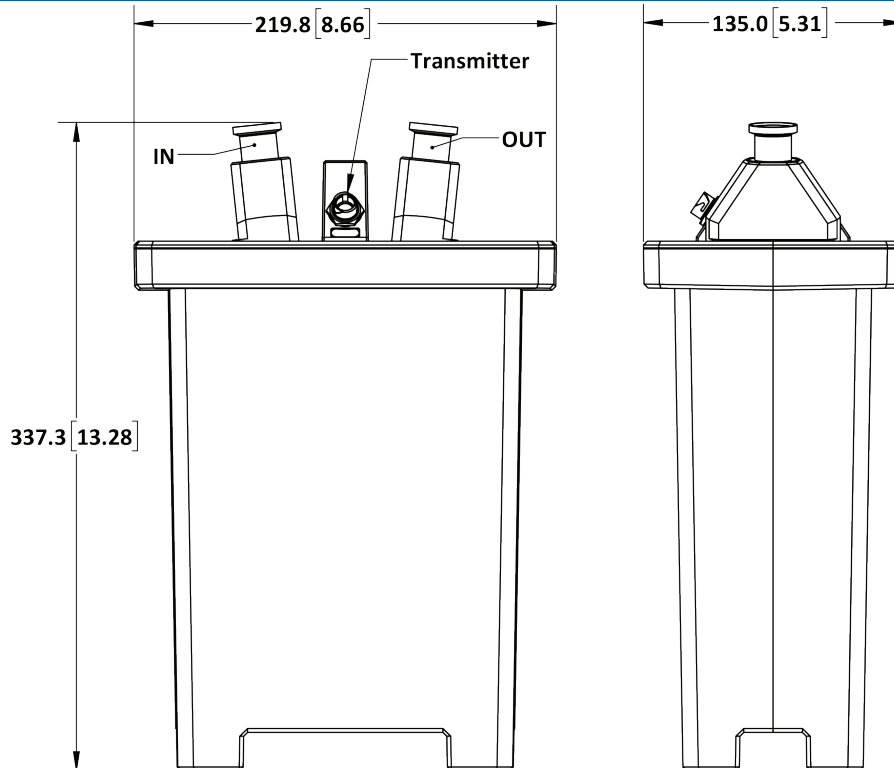

Dimensional Drawings

For reference only

Note: Mounting Cradle is required for CE compliance

CSEN-8103-CA152 Sensor (6 – 60 kg/min or l/min, 3/4" Barb)

3/4" Barb Connections, Standard Vertical Inlets Configuration

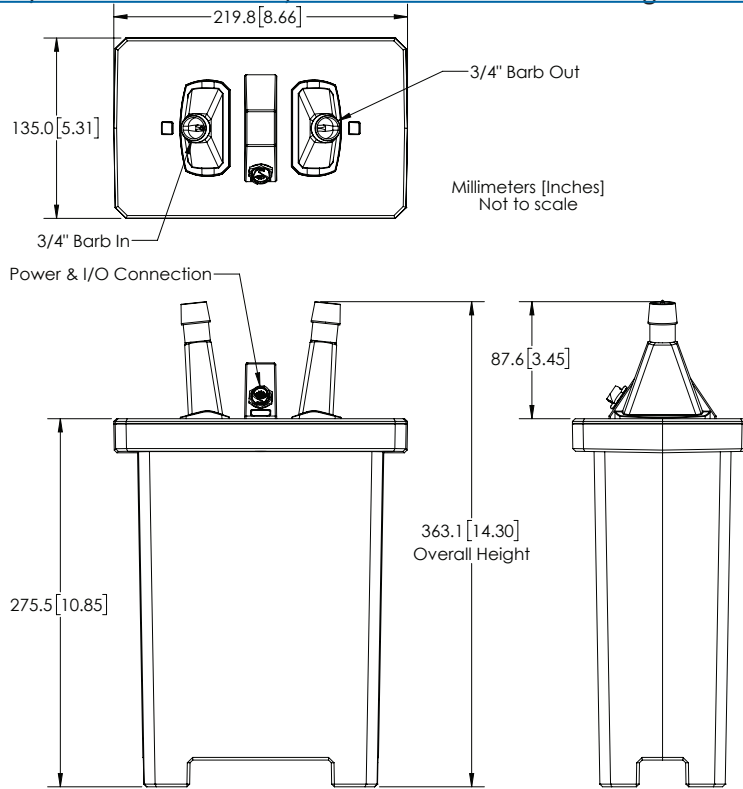

C
3/4"
BARB

CSEN-8103-CA153 Sensor (10 – 100 kg/min or l/min, 1" TC)

1" - 1 1/2" Tri-Clamp Connections, Standard Vertical Inlets Configuration

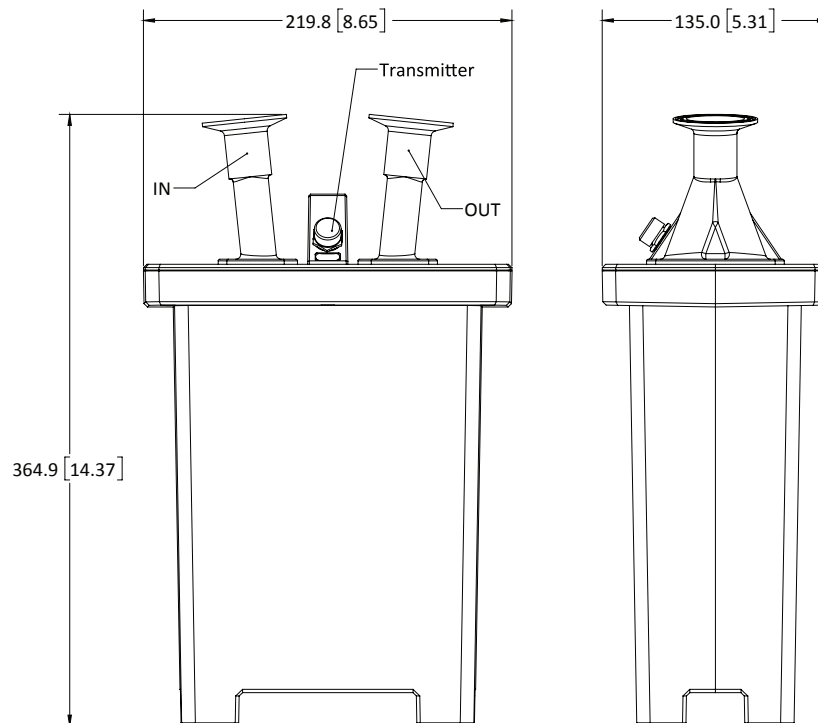

C
1"
TC

Dimensional Drawings

For reference only

Note: Mounting Cradle is required for CE compliance

CSEN-8103-CA153 Sensor (10 – 100 kg/min or l/min, 1" Barb)

1" Barb Connections, Standard Vertical Inlets Configuration

C

1" BARB

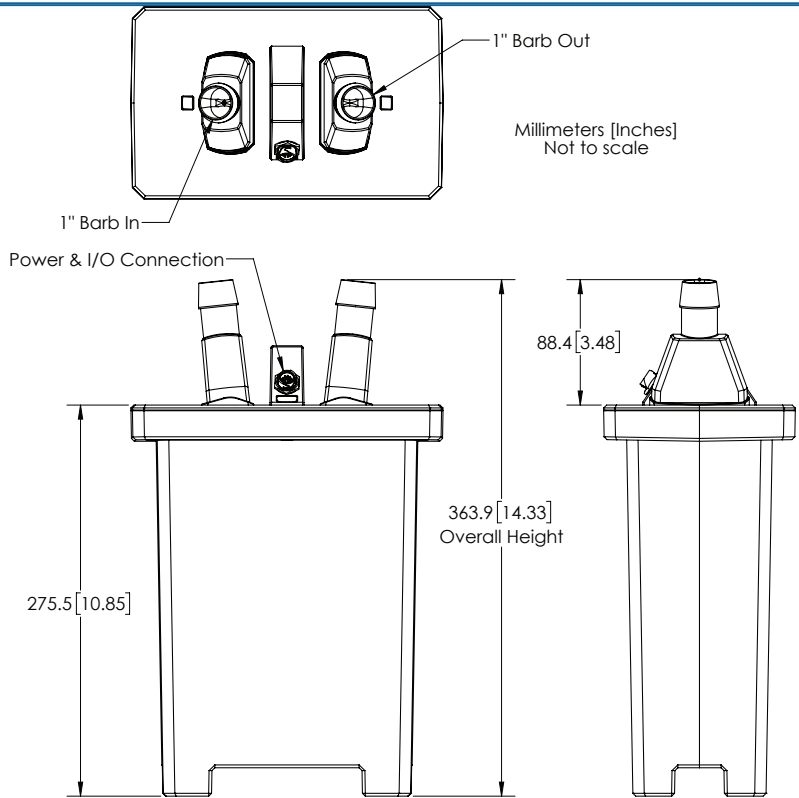

Dimensional Drawings

For reference only

Note: Mounting Cradle is required for CE compliance

CSEN-8103-PV062 Sensor (0.5 – 5 kg/min or l/min, 1/4")
 1/4" Barb Connections, Panel Mount Configuration

P
 1/4"
 BARB

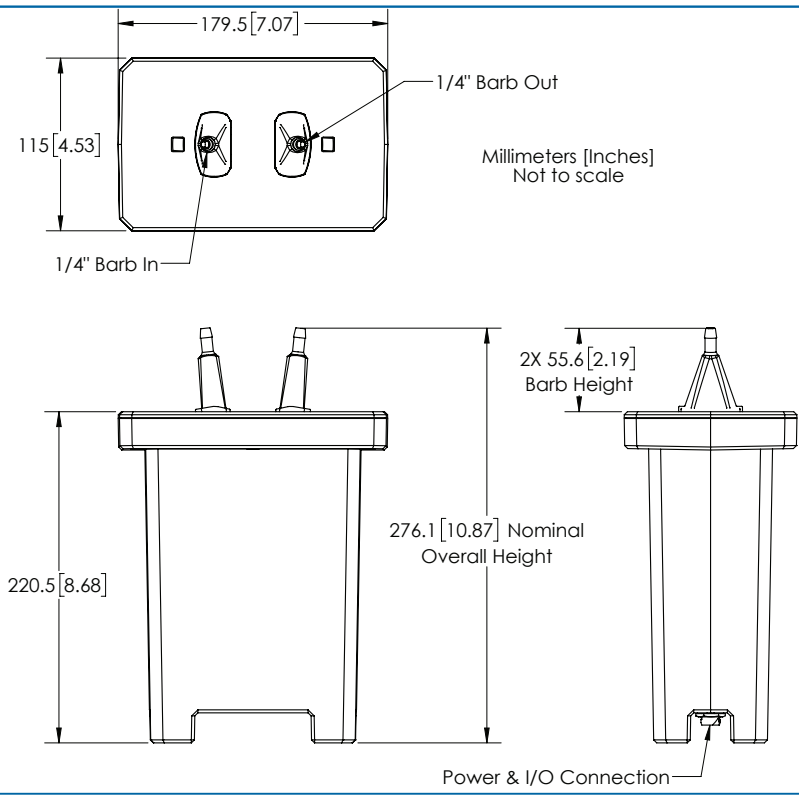

CSEN-8103-PV063 Sensor (0.9 – 9 kg/min or l/min, 3/8")
 3/8" Barb Connections, Panel Mount Configuration

P
 3/8"
 BARB

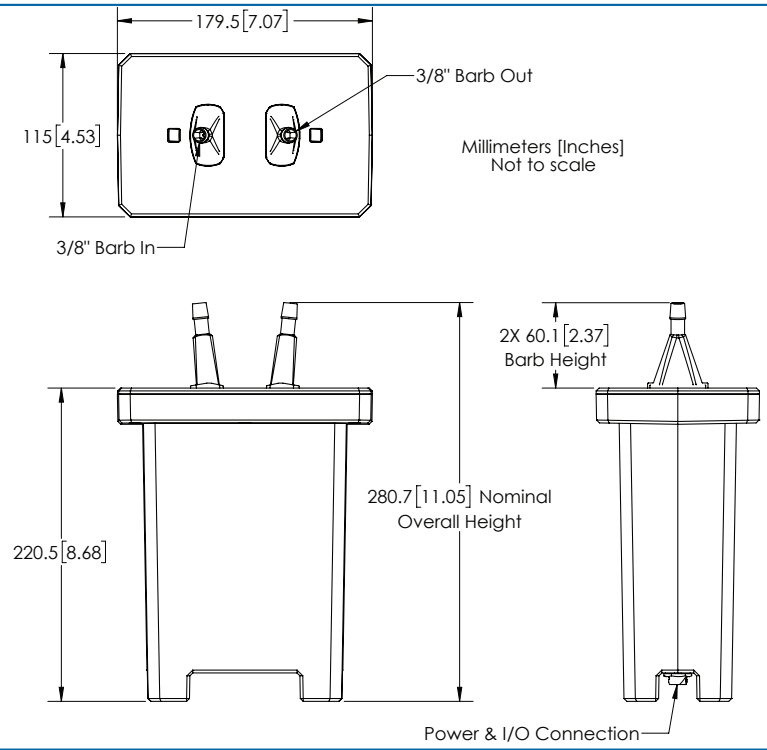

Dimensional Drawings

For reference only

Note: Mounting Cradle is required for CE compliance

CSEN-8103-PV082 Sensor (2 – 20 kg/min or l/min, 1/2")
 1/2" Barb Connections, Panel Mount Configuration

P
 1/2"
 BARB

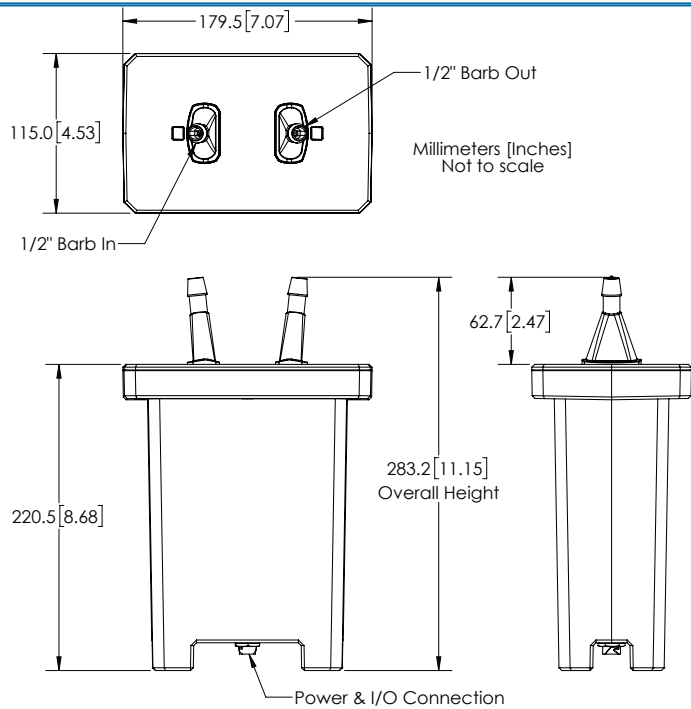

CSEN-8103-PV152 Sensor (6 – 60 kg/min or l/min, 3/4")
 3/4" Barb Connections, Panel Mount Configuration

P
 3/4"
 BARB

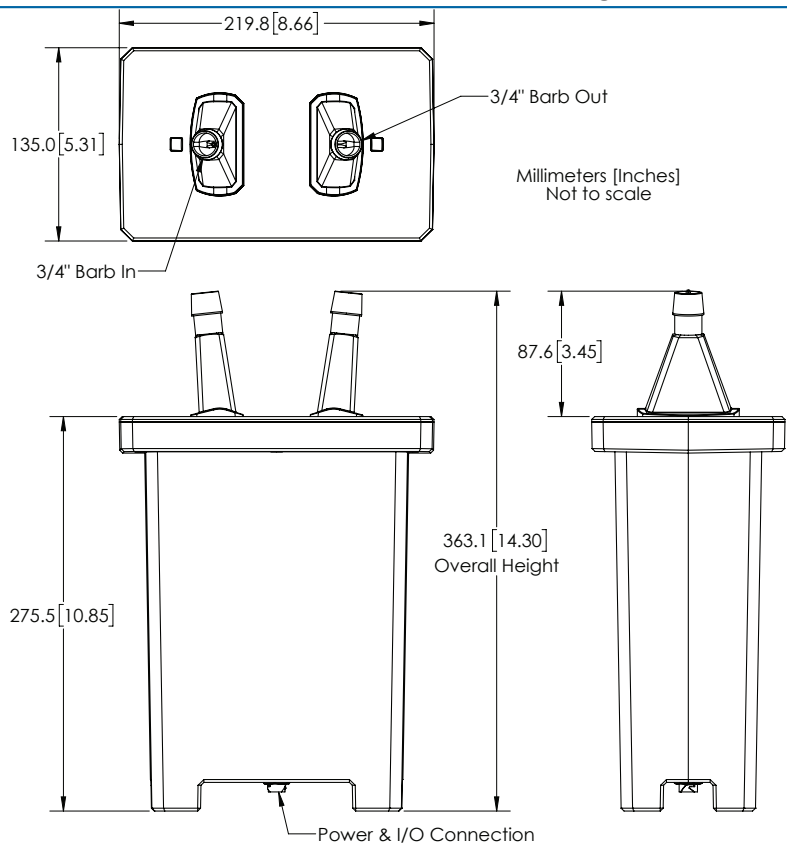

Dimensional Drawings

For reference only

Note: Mounting Cradle is required for CE compliance

CSEN-8103-PV153 Sensor (10 – 100 kg/min or l/min, 1")

1" Barb Connections, Panel Mount Configuration

P
1" BARB

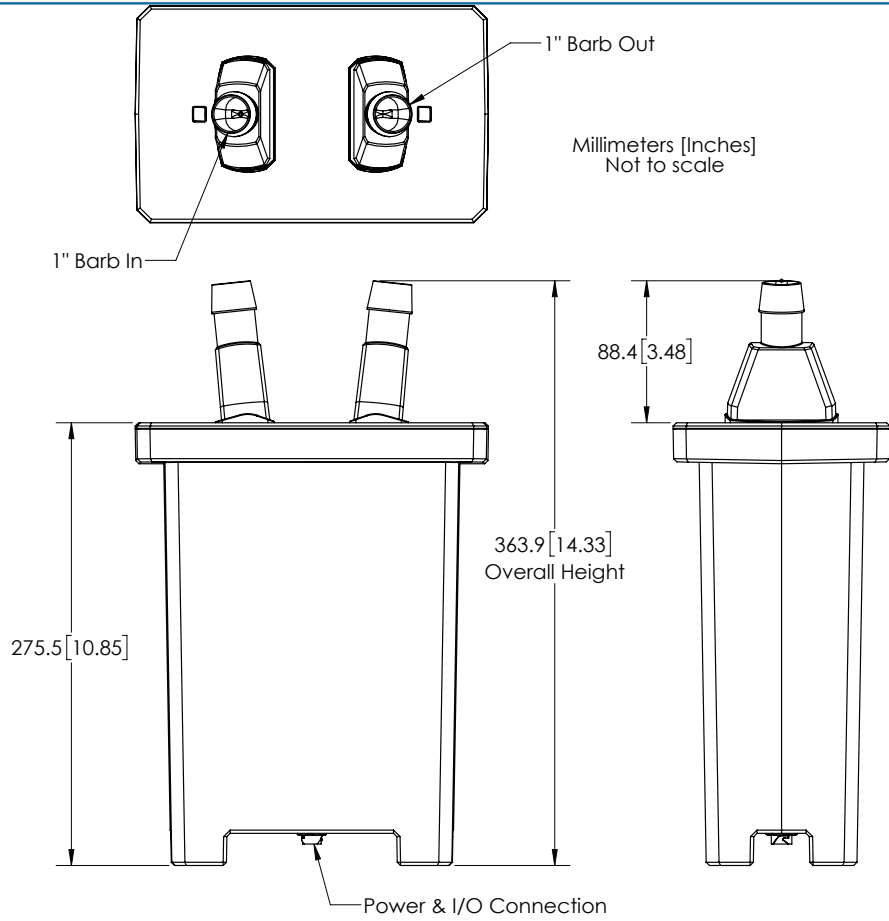

Dimensional Drawings

For reference only

Note: Mounting Cradle is required for CE compliance

CSEN-8103-TV063 Sensor (0.18 – 9 kg/min or l/min, 3/8")

3/8" Barb Connections, Added height Inline Configuration

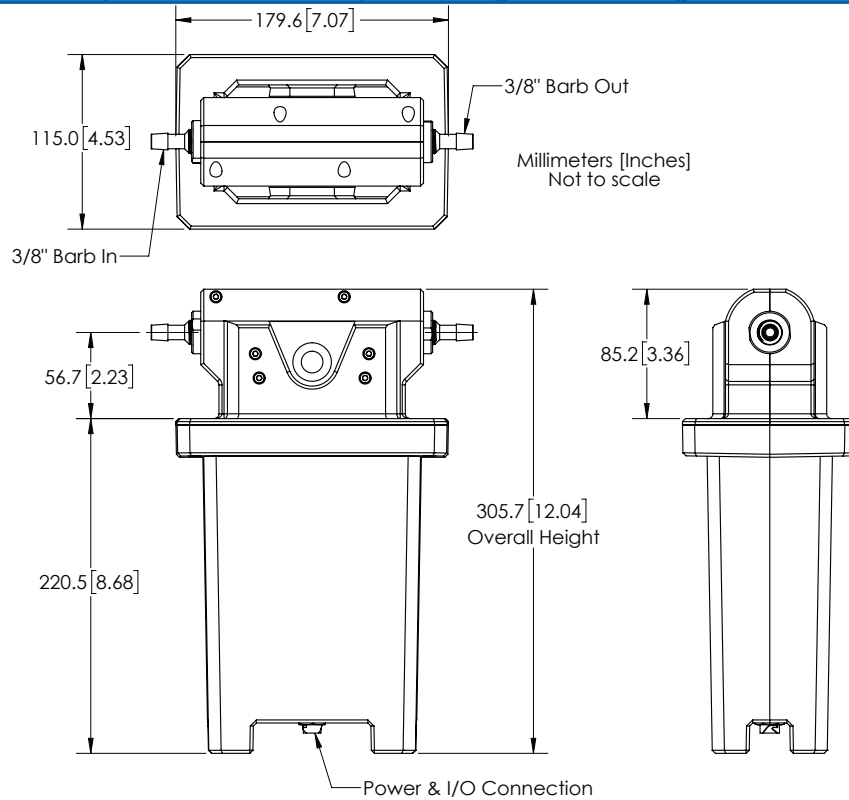

T
3/8"
BARB

CSEN-8103-TV082 Sensor (0.4 – 20 kg/min or l/min, 1/2")

1/2" Barb Connections, Added height Inline Configuration

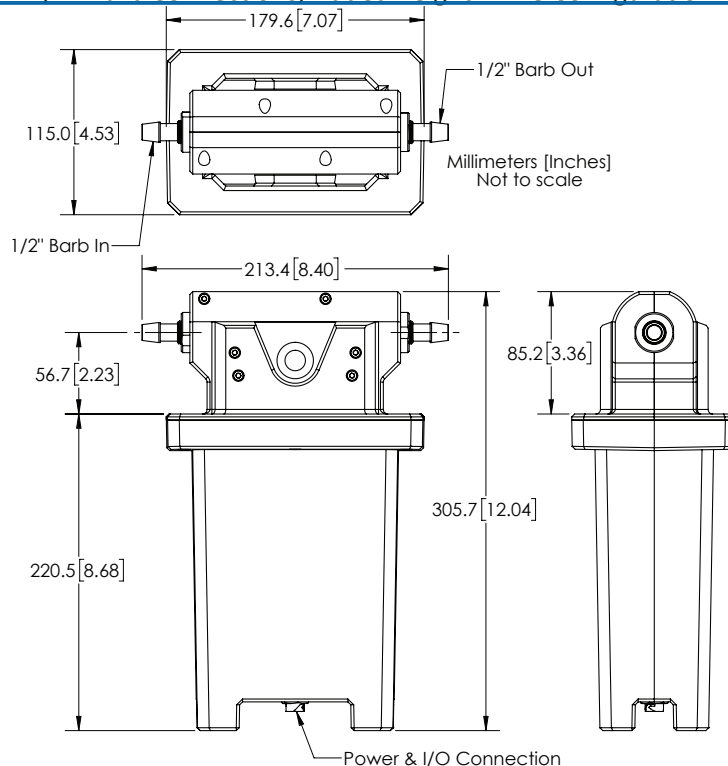

T
1/2"
BARB

Dimensional Drawings

For reference only

Note: Mounting Cradle is required for CE compliance

ENCL-MOUNT-8103-U08-001

Mounting Cradle for 1/8" sensors

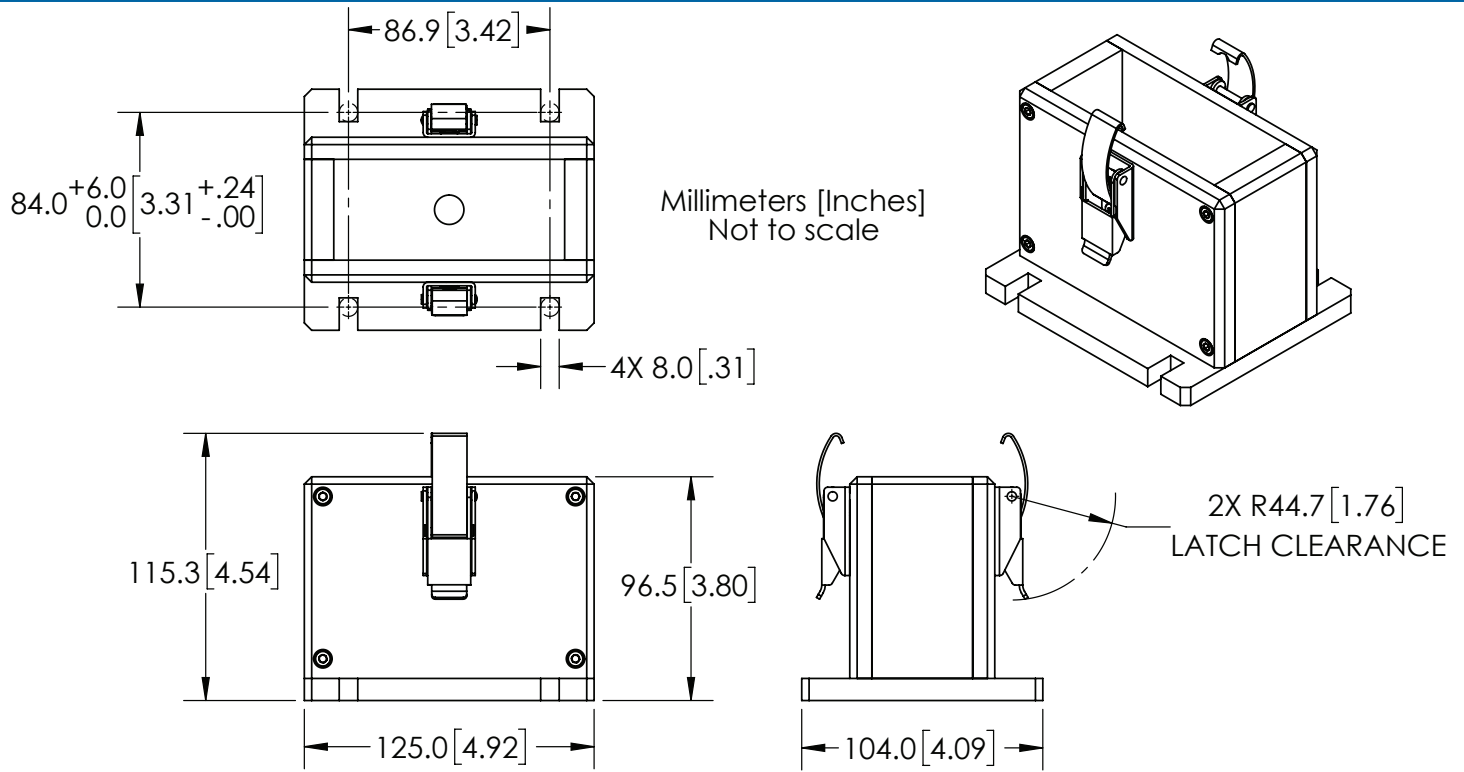

Dimensional Drawings

For reference only

Note: Mounting Cradle is required for CE compliance

ENCL-MOUNT-8103-08HC-XXXF

Mounting Flange 1/4", 3/8", and 1/2" Sensors

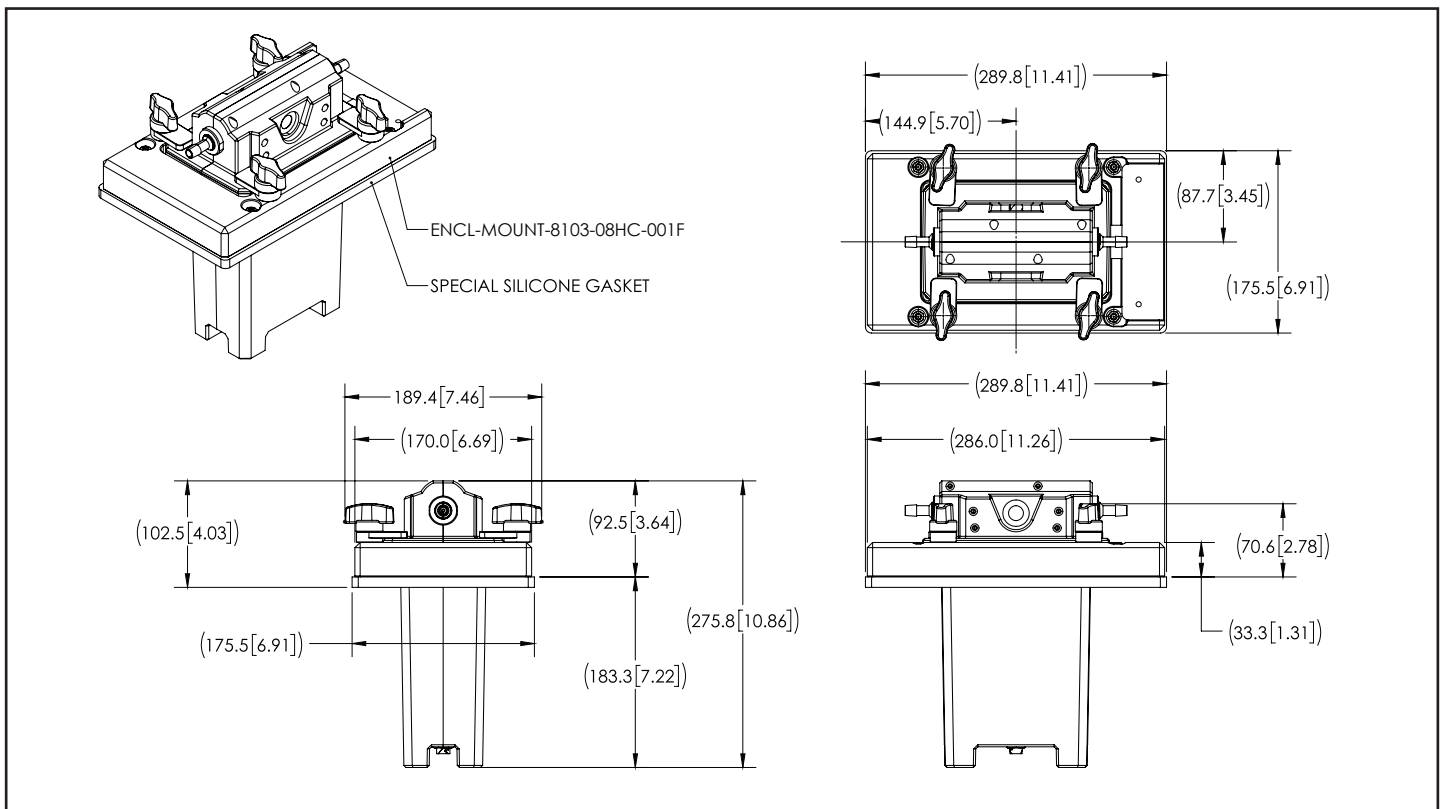
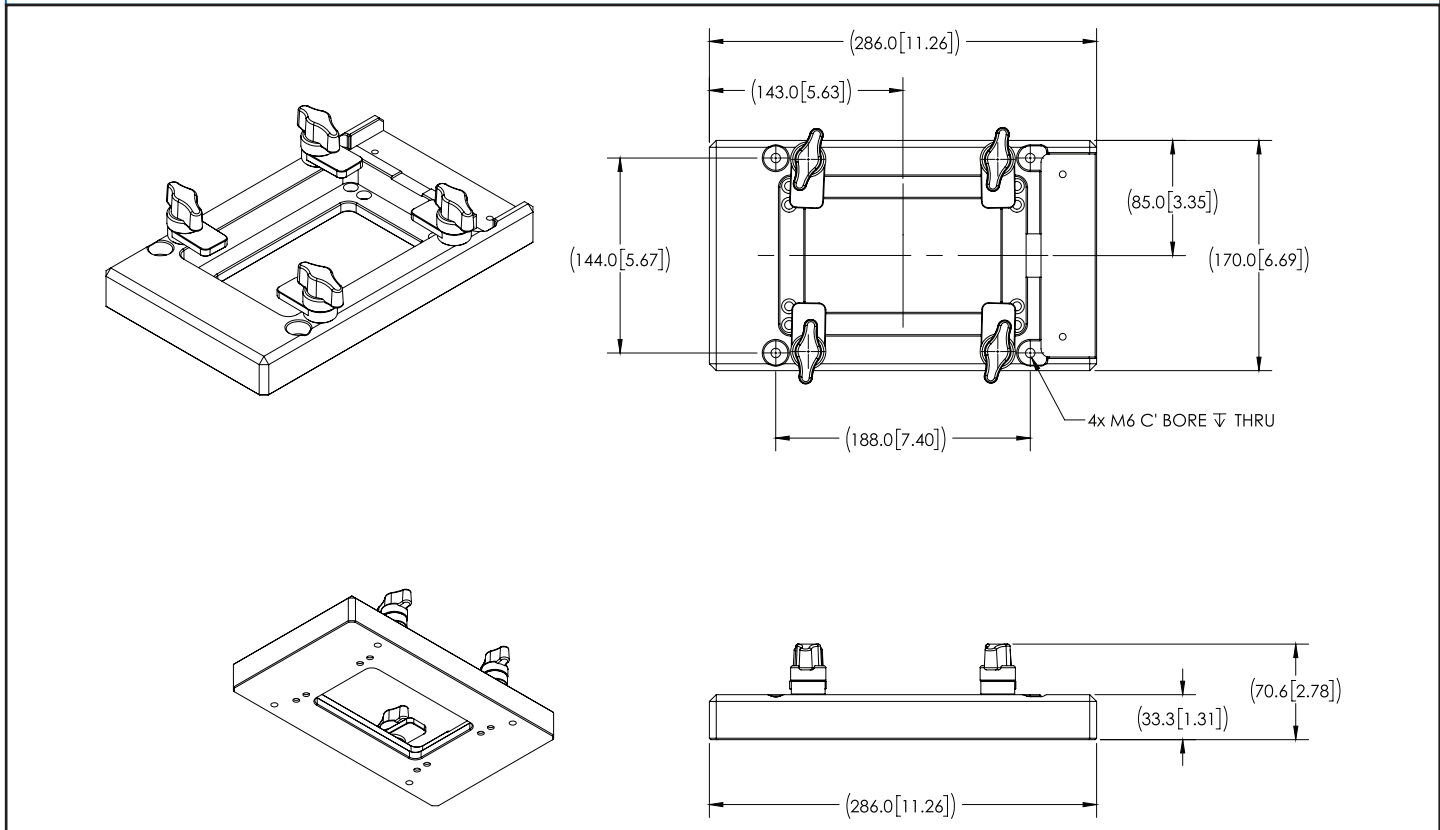

Dimensional Drawings

For reference only

Note: Mounting Cradle is required for CE compliance

ENCL-MOUNT-8103-08HC-XXX

Heavy Cradle 1/4", 3/8", and 1/2" Sensors

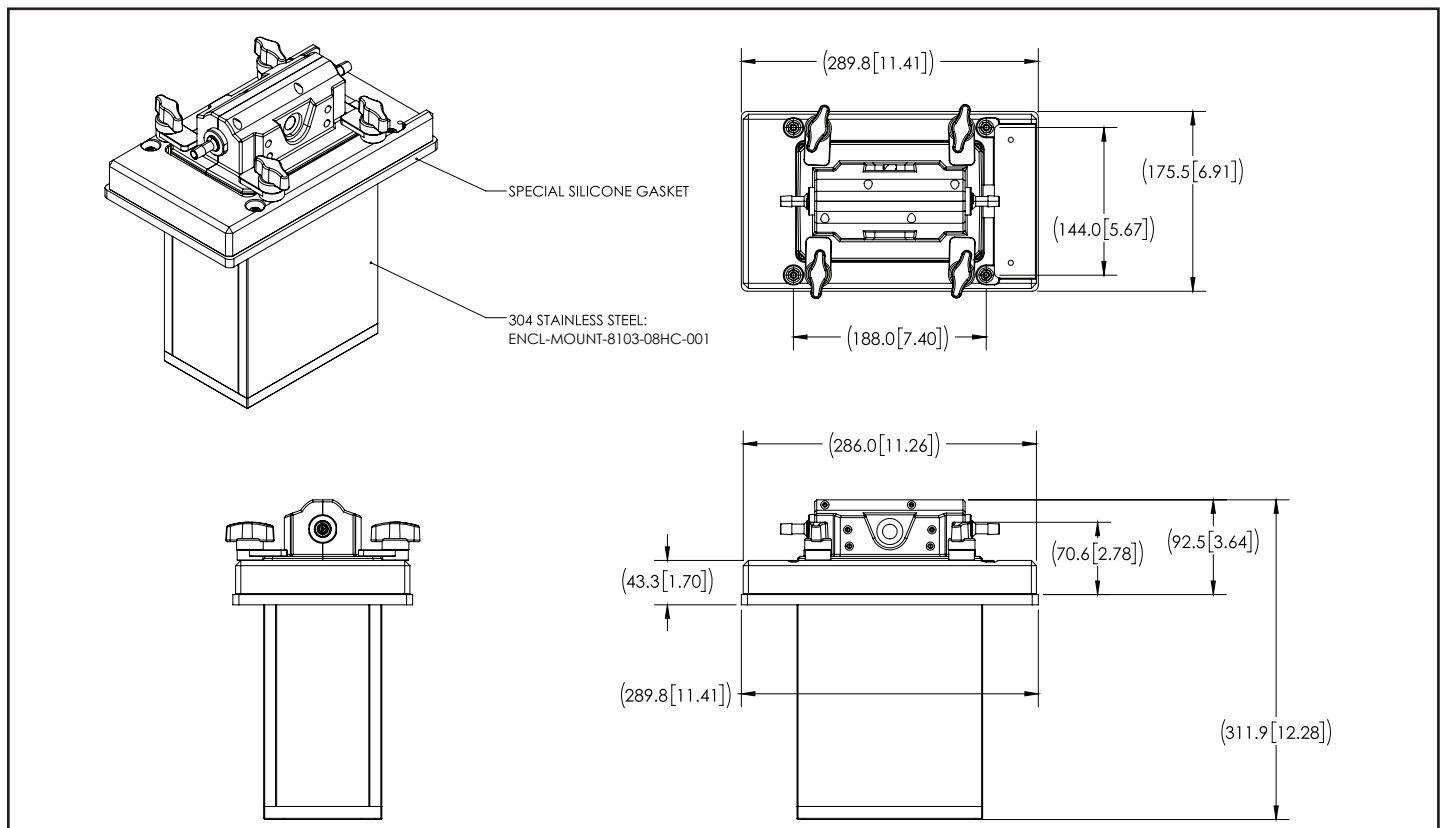
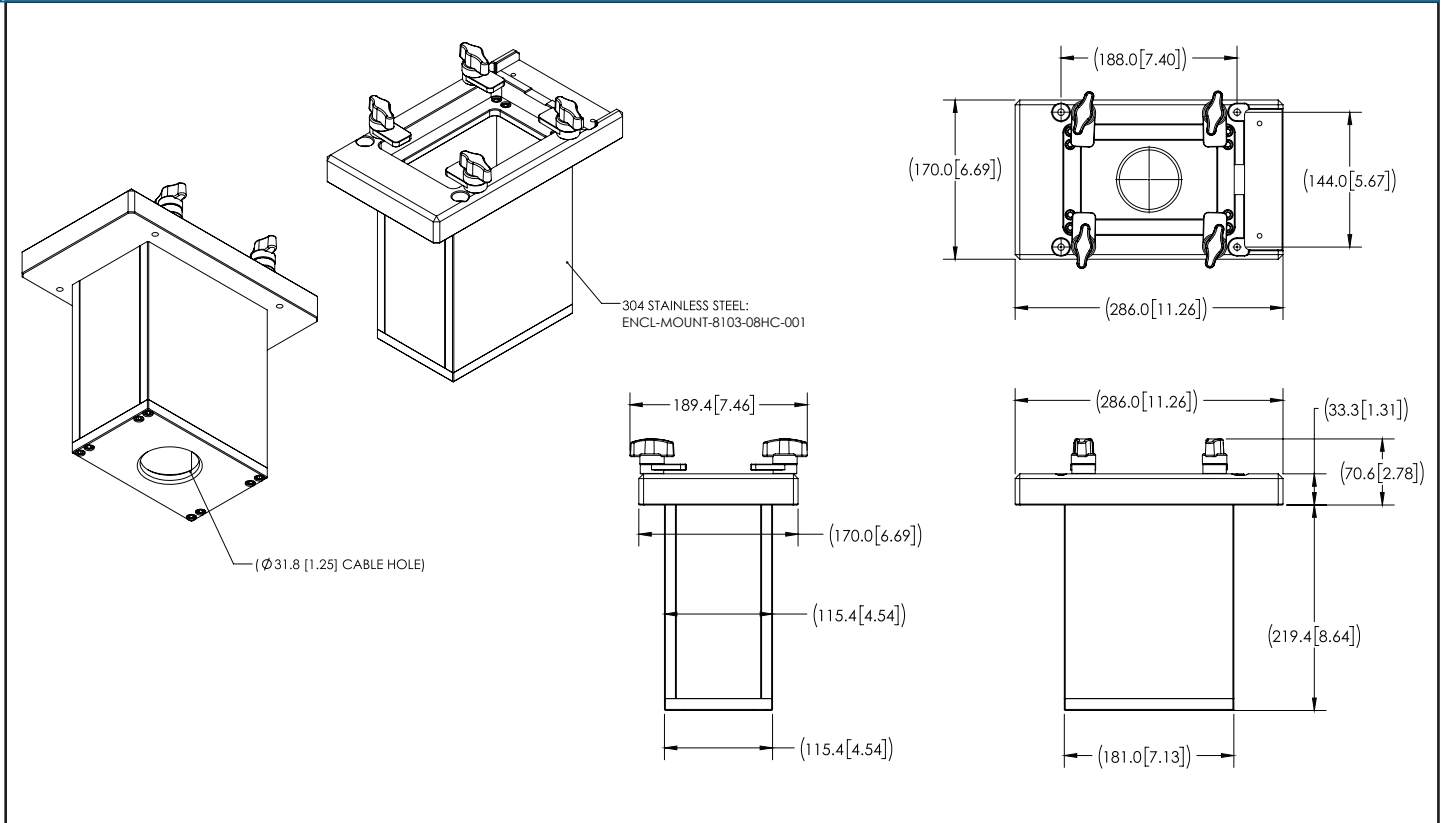

Dimensional Drawings

For reference only

Note: Mounting Cradle is required for CE compliance

ENCL-MOUNT-8103-15HC-XXXF

Mounting Flange 3/4" and 1" Sensors

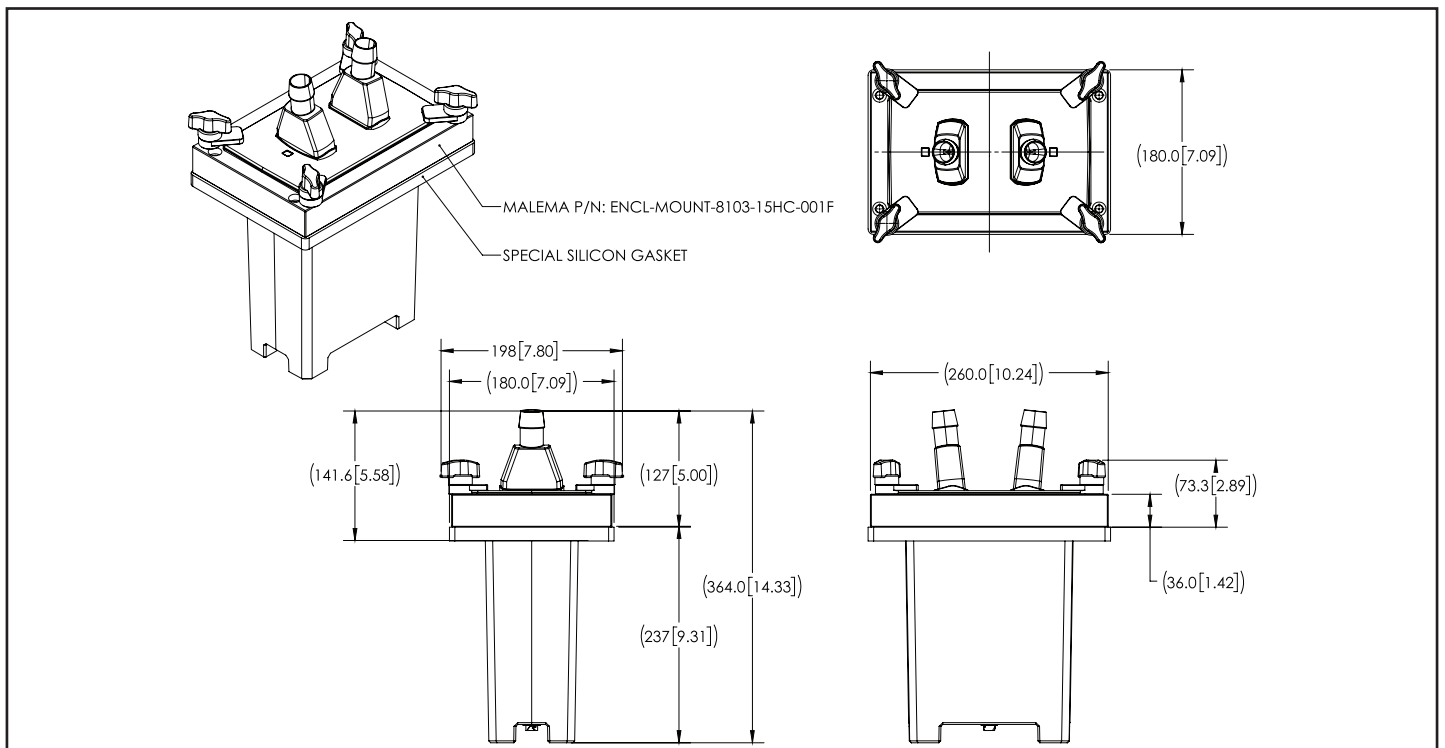
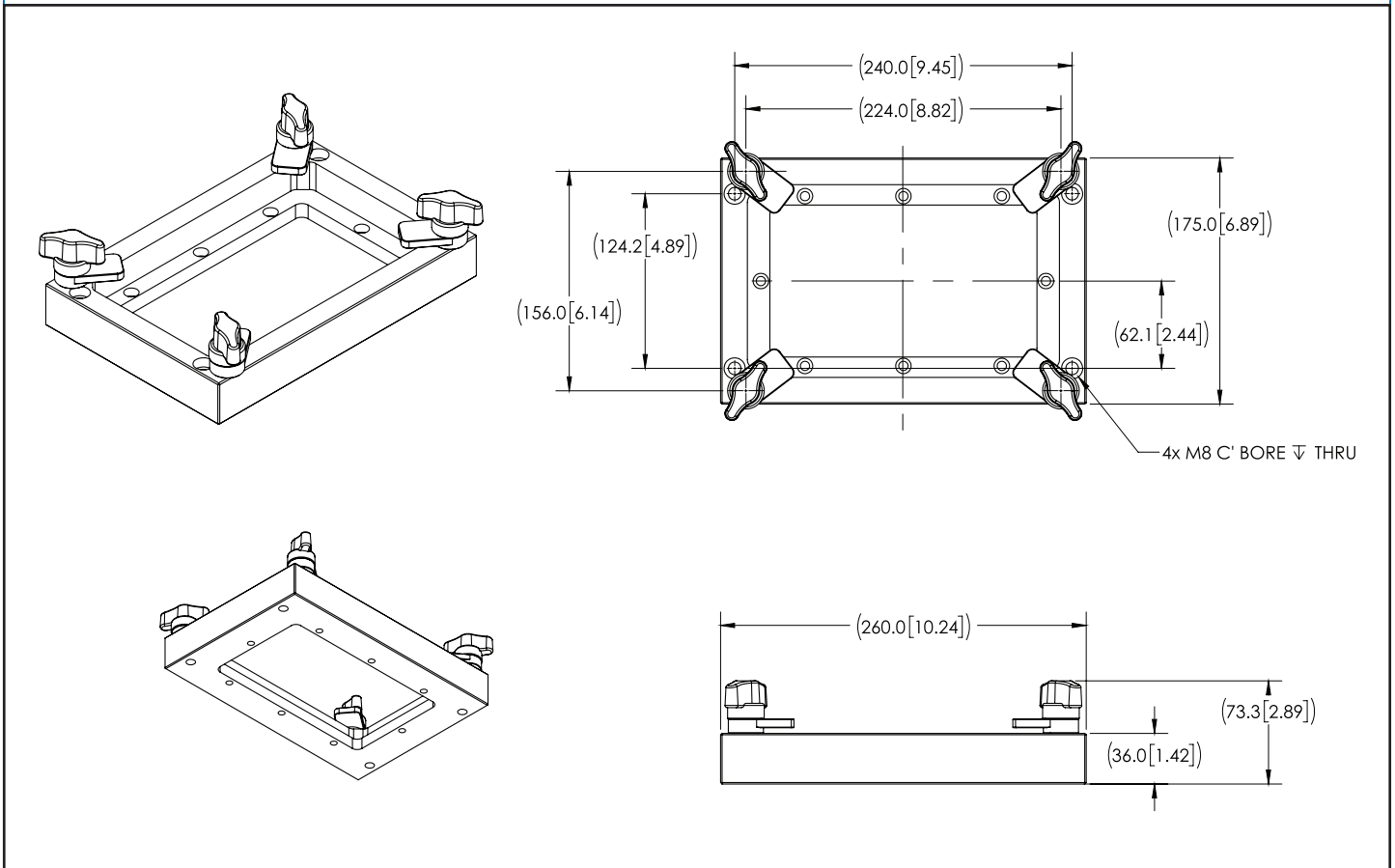

Dimensional Drawings

For reference only

Note: Mounting Cradle is required for CE compliance

ENCL-MOUNT-8103-15HC-XXX

Heavy Cradle 3/4" and 1" Sensors

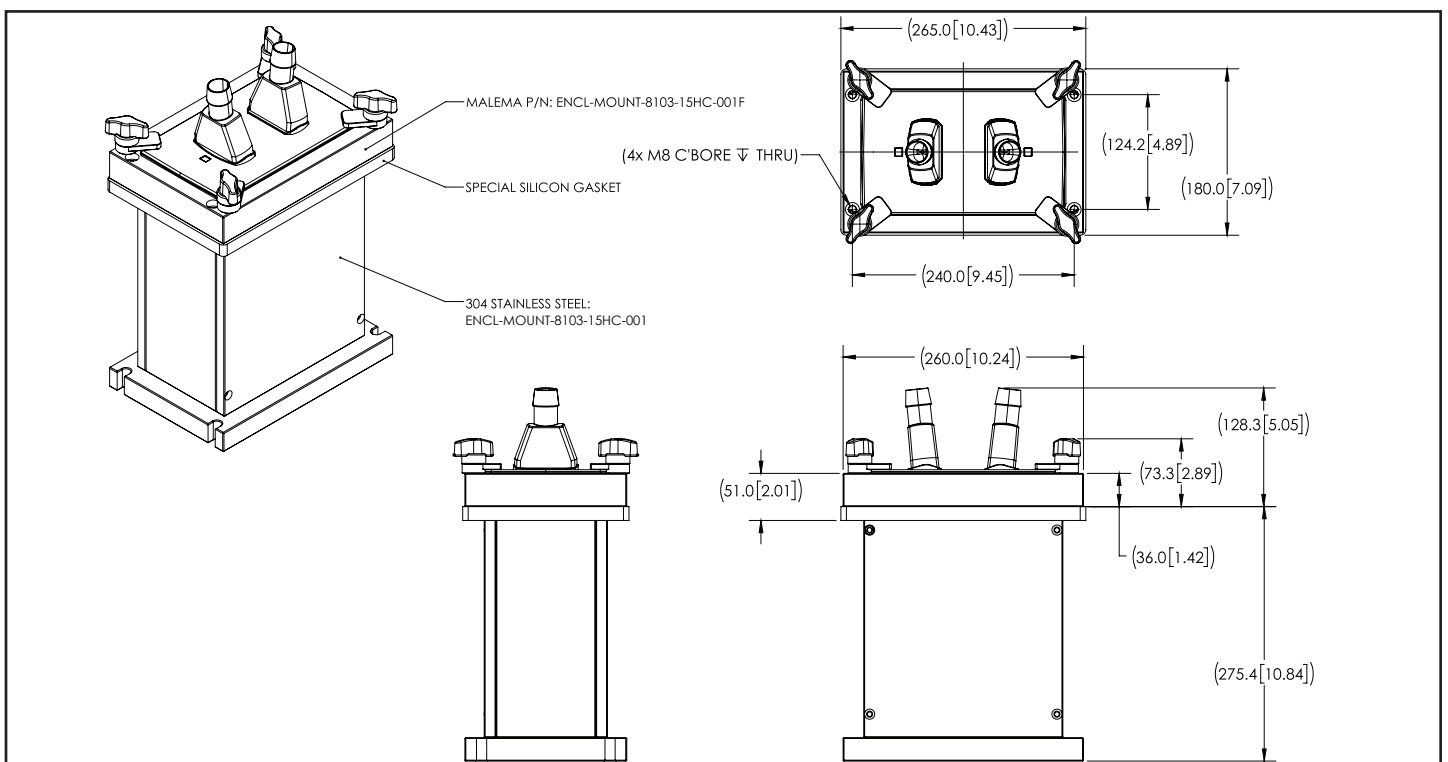
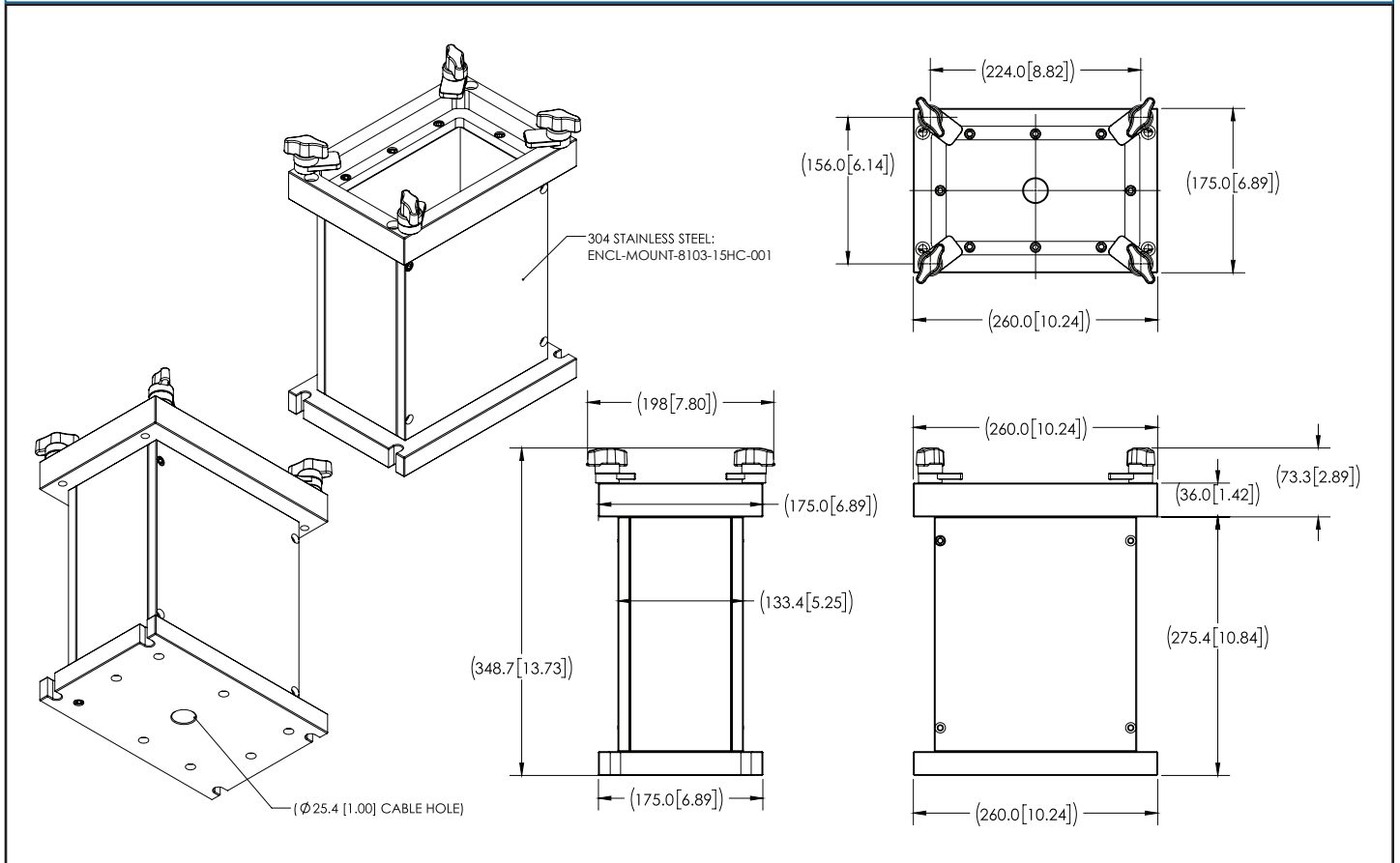

For reference only

Note: Mounting Cradle is required for CE compliance

8MM CRADLE ASSEMBLY INSTALLATION ON THE SKID

Heavy Cradle 1/4", 3/8", and 1/2" Sensors

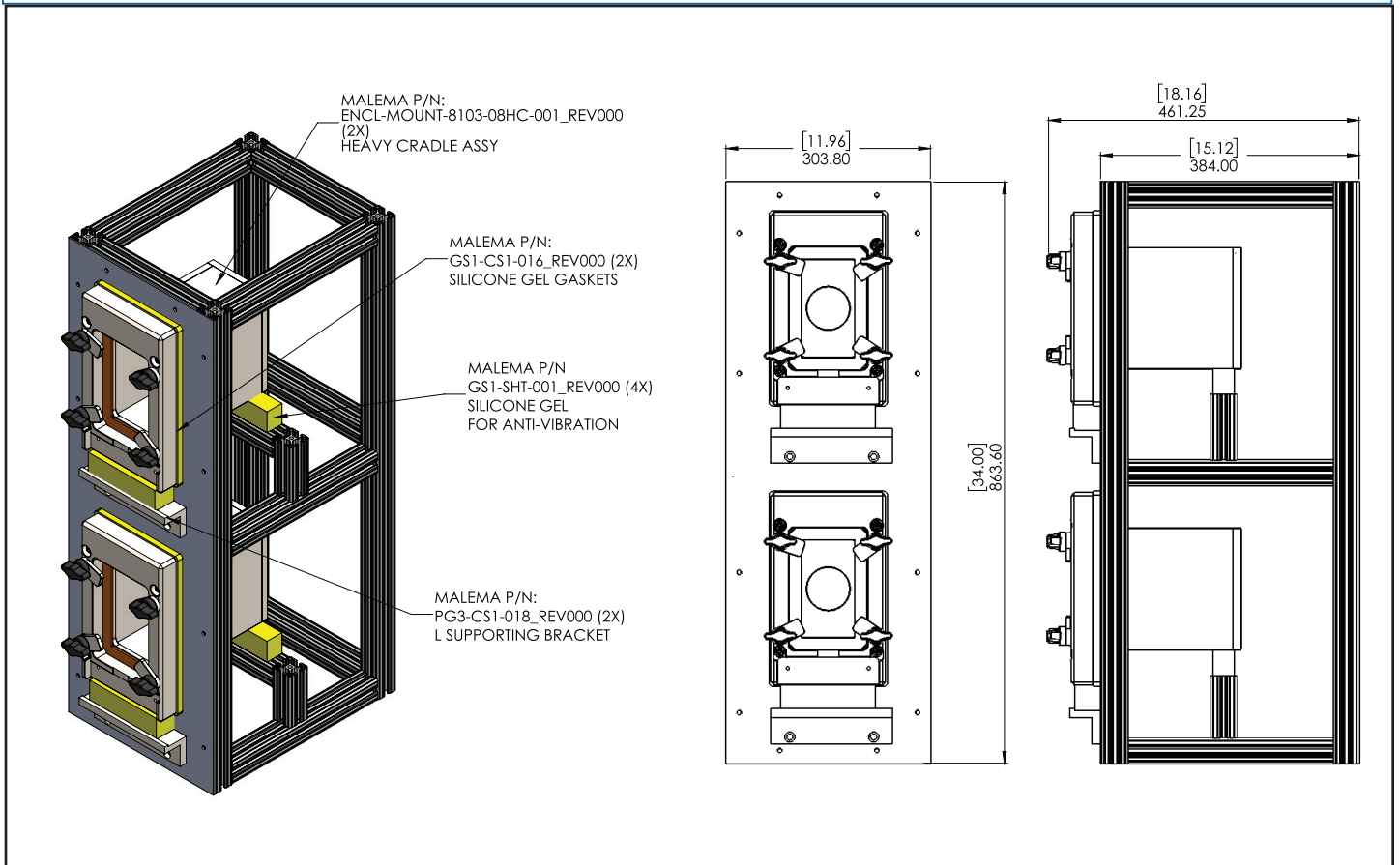

Dimensional Drawings

For reference only

Note: Mounting Cradle is required for CE compliance

15MM CRADLE ASSEMBLY INSTALLATION ON THE SKID

Heavy Cradle 3/4" and 1" Sensors

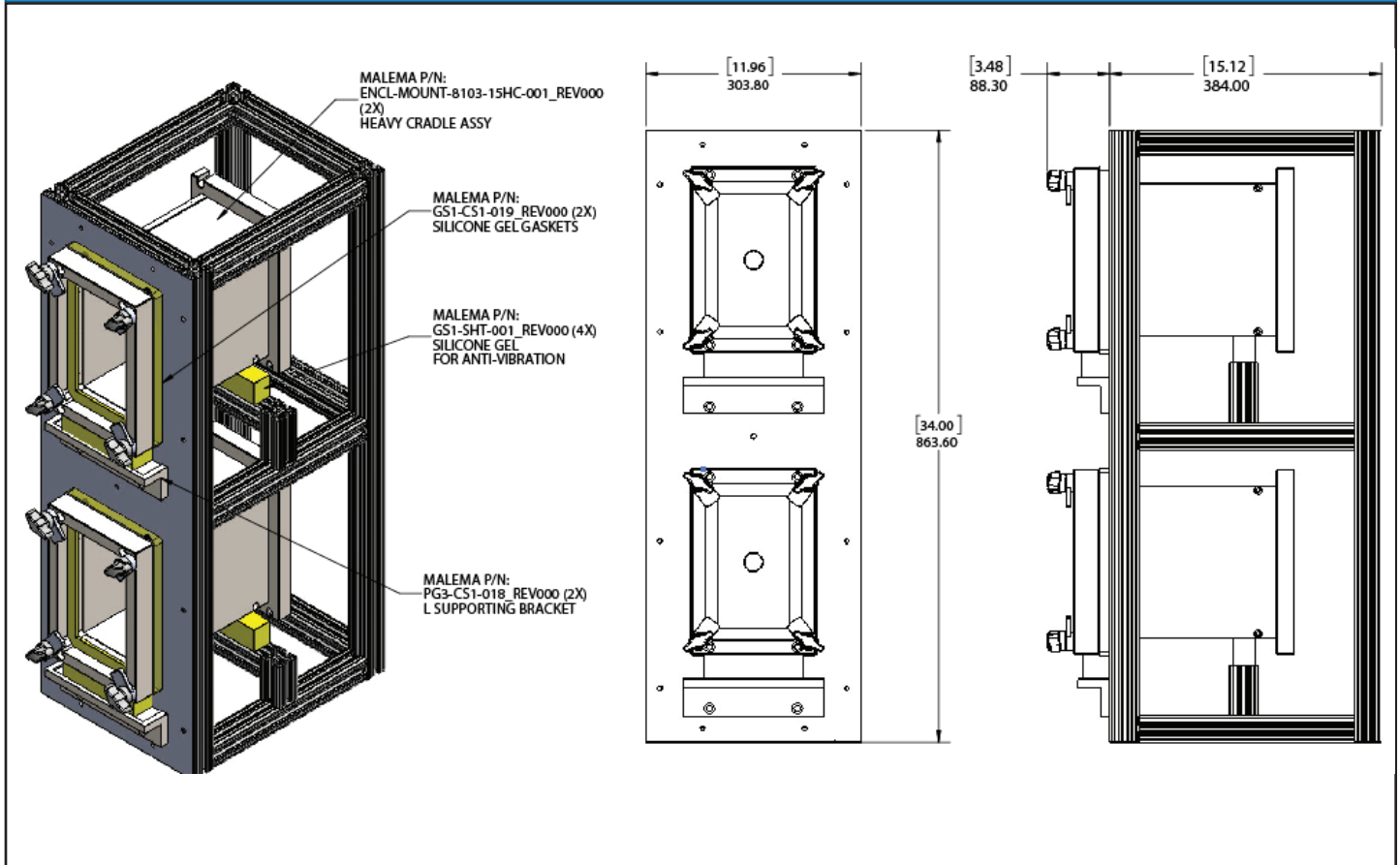

Pressure Drop in DI Water

Test Conditions: DI Water at 25°C

Sensor Range Code 031 (1/8" barb)	
Flow Rate	Pressure Drop
50 g/min	0.01 psi (0.08 kPa)
150 g/min	0.10 psi (0.69 kPa)
400 g/min	0.71 psi (4.90 kPa)
800 g/min	2.84 psi (19.61 kPa)
1200 g/min	6.40 psi (44.13 kPa)
1500 g/min	10.00 psi (68.95 kPa)

Sensor Range Code 062 (1/4" barb)	
Flow Rate	Pressure Drop
500 g/min	0.10 psi (0.69 kPa)
750 g/min	0.23 psi (1.55 kPa)
1500 g/min	0.90 psi (6.21 kPa)
2500 g/min	2.50 psi (17.24 kPa)
3750 g/min	5.63 psi (38.78 kPa)
5000 g/min	10.00 psi (68.95 kPa)

Sensor Range Code 063 (3/8" barb)	
Flow Rate	Pressure Drop
900 g/min	0.10 psi (0.69 kPa)
1688 g/min	0.35 psi (2.42 kPa)
3375 g/min	1.40 psi (9.70 kPa)
5063 g/min	3.16 psi (21.82 kPa)
6750 g/min	5.63 psi (38.78 kPa)
9000 g/min	10.00 psi (68.95 kPa)

Sensor Range Code 082 (1/2" barb)	
Flow Rate	Pressure Drop
2000 g/min	0.10 psi (0.69 kPa)
5000 g/min	0.63 psi (4.31 kPa)
7500 g/min	1.41 psi (9.70 kPa)
10000 g/min	2.50 psi (17.24 kPa)
15000 g/min	5.63 psi (38.78 kPa)
20000 g/min	10.00 psi (68.95 kPa)

Sensor Range Code 152 (3/4" barb)	
Flow Rate	Pressure Drop
6000 g/min	0.10 psi (0.69 kPa)
12000 g/min	0.40 psi (2.76 kPa)
21000 g/min	1.23 psi (8.45 kPa)
35000 g/min	3.40 psi (23.46 kPa)
50000 g/min	6.94 psi (47.88 kPa)
60000 g/min	10.00 psi (68.95 kPa)

Sensor Range Code 153 (1" barb)	
Flow Rate	Pressure Drop
10000 g/min	0.10 psi (0.69 kPa)
20000 g/min	0.40 psi (2.76 kPa)
50000 g/min	2.50 psi (17.24 kPa)
75000 g/min	5.63 psi (38.78 kPa)
87000 g/min	7.57 psi (52.19 kPa)
100000 g/min	10.00 psi (68.95 kPa)

Model Ordering Code												Description	
CSEN-8103	-	*	*	***	*	*	*	*	*	-	*	***	PEEK Sensor
Sensor Type	C												Standard Vertical inlet and outlet ports
	P												Panel Mount Vertical inlet and outlet ports
	R												Inline inlet and outlet ports
	T												Tall inline inlet and outlet ports (-063 and -082 only)
Electrical Connector	A												Electrical connection on lid (top)
	V												Electrical connection on cup (bottom)
Range Code	031												0.05 – 1.5 kg/min
	062												0.5 - 5 kg/min for C & P, 0.15 - 5 kg/min for R
	063												0.9 - 9 kg/min for C & P, 0.18- 9 kg/min for R & T
	082												2 - 20 kg/min for C & P, 0.4 - 20 kg/min for R & T
	152												6 - 60 kg/min
	153												10 - 100 kg/min
Temperature Sensor	W												External Temp. Sensor (Range code 031 only)
	I												Integrated Internal Temp Sensor (all other range codes)
Sterilization	0												No Sterilization
	1												Gamma Irradiated to 25 - 40 kGy
	Z												Other Requests (Consult Factory)
Fluid Connections	A												1/8" Hose Barb (Range code 031)
	B												1/8" Hose Barb with Tubing (Range code 031)
	E												1/4" Barb (RC 062)
	F												1/4" Barb with Tubing (RC 062)
	H												3/8" Barb (RC 063)
	J												3/8" Barb with Tubing (RC 063)
	K												3/8" to Mini TC (RC 063)
	L												1/2" Barb (RC 082)
	M												1/2" Barb with Tubing (RC 082)
	N												1/2" to Mini TC (RC 082)
	P												3/4" Barb (RC 152)
	Q												3/4" Barb with Tubing (RC 152)
	R												3/4" to Mini TC (RC 152)
	S												1" Barb (RC 153)
	T												1" Barb with Tubing (RC 153)
	U												1" to 1-1.5" TC (RC 153)
	Z												Custom fluid connection (please consult factory)
Mounting Orientation	H												Horizontal *
	V												Vertical (flow ports pointing upwards)**
Calibrations and Outputs	1												Calibrated for Mass Flow Rate Only
	2												Density Measurement Enabled, Analog Output 1 for Volumetric Flow Rate
	3												Density Measurement Enabled, Analog Output 1 for Density
	4												Density Measurement Enabled, Analog Output 1 for Mass Flow Rate
Firmware	A												Version 3.3.0R
	B												Version 3.3.2R
	C												Version 3.3.3R
	D												Version 3.3.5R
											XXX	Unique PN Identifier	

* Factory recommended option for all sizes except RC 031

** Factory recommended option for RC 031

Ordering Information - Electronics

Model Ordering Code														Description			
CELE-8103	-	*	-	*	*	*	*	*	*	X	X	X	-	*	***	Transmitter	
		C													DIN Rail Mounting (Non Display Only; CE)		
		Z													Custom (Consult Factory)		
Temperature Compensation		-	T													Use with Temperature Comp Sensors	
		Z													Custom (Consult Factory)		
Output		1														1x 4-20mA, 1x D/O	
		2														1x 4-20mA, 2x D/O	
		3														1x 4-20mA, 1x D/O, MODBUS (RS485)	
		7														4x 4-20 mA, 0x D/O	
		8														2x 4-20 mA, 1x D/O, MODBUS (RS485) (i.e. analog for flow rate and density)	
		9														3x 4-20 mA, 1x D/O (i.e. analog output for flow rate, density, temperature)	
		Z														Custom (Consult Factory)	
I/O Cable		0														Standard I/O Cable	
		Z														Custom (Consult Factory)	
I/O Cable Length		A														3 m	
		Z														Custom (Consult Factory)	
Interconnecting Cable Length		A														3 m	
		Z														Custom (Consult Factory)	
Measurement		X														For Use with Sensors Calibrated for Mass Flow Rate Only	
		D														For Use with Sensors Calibrated for Density and/or Volumetric Flow Rate	
		X														Reserved for Factory	
		X														Reserved for Factory	
Firmware		A														Version 3.3.0R	
		B														Version 3.3.2R	
		C														Version 3.3.3R	
		D														Version 3.3.5R	
		XXX														Unique PN Identifier	

Ordering Information - Mounting Cradle

Model Ordering Code						Description	
ENCL-MOUNT-8103	-	**	-	***	Mounting Cradle		
Size		U08		For use with Sensor Range Code 031			
		8HC		For use with Sensor Range Code 062, 063, 082			
		15HC		For use with Sensor Range Code 152, 153			
		-					
		XXX		Unique PN Identifier			
		XXXF		Unique PN Identifier for Flanged Version			

© 2022 Malema Engineering Corporation. All rights reserved.

Malema Sensors and SumoFlo are registered trademarks of Malema Engineering Corporation. Malema, the Malema logo, Malema Engineering Corporation, and the SumoFlo logo are trademarks of Malema Engineering Corporation. All other trademarks are property of their respective owners.

Malema supplies this publication for informational purposes only. While every effort has been made to ensure accuracy, this publication is not intended to make performance claims or process recommendations. Malema does not warrant, guarantee, or assume any legal liability for the accuracy, completeness, timeliness, reliability, or usefulness of any information, product, or process described herein. We reserve the right to modify or improve the designs or specifications of our products at any time without notice. For actual product information and recommendations, please contact your local Malema representative.

Corporate Headquarters

1060 S Rogers Circle
Boca Raton, FL 33487

P: (561) 995-0595 F: (561) 995-0622

West Coast Headquarters

2329 Zanker Road
San Jose, CA 95131

P: (408) 970-3419 F: (408) 970-3426

Asia Pacific Headquarters

35 Marsiling Industrial Estate 3, Unit #02-06
Singapore 739257

P: (65) 6482-3533 F: (65) 6484-4231